

 **LOGOSOL**

# ASENNUSOHJE

Tuotenro 0458-395-0424

REV:1

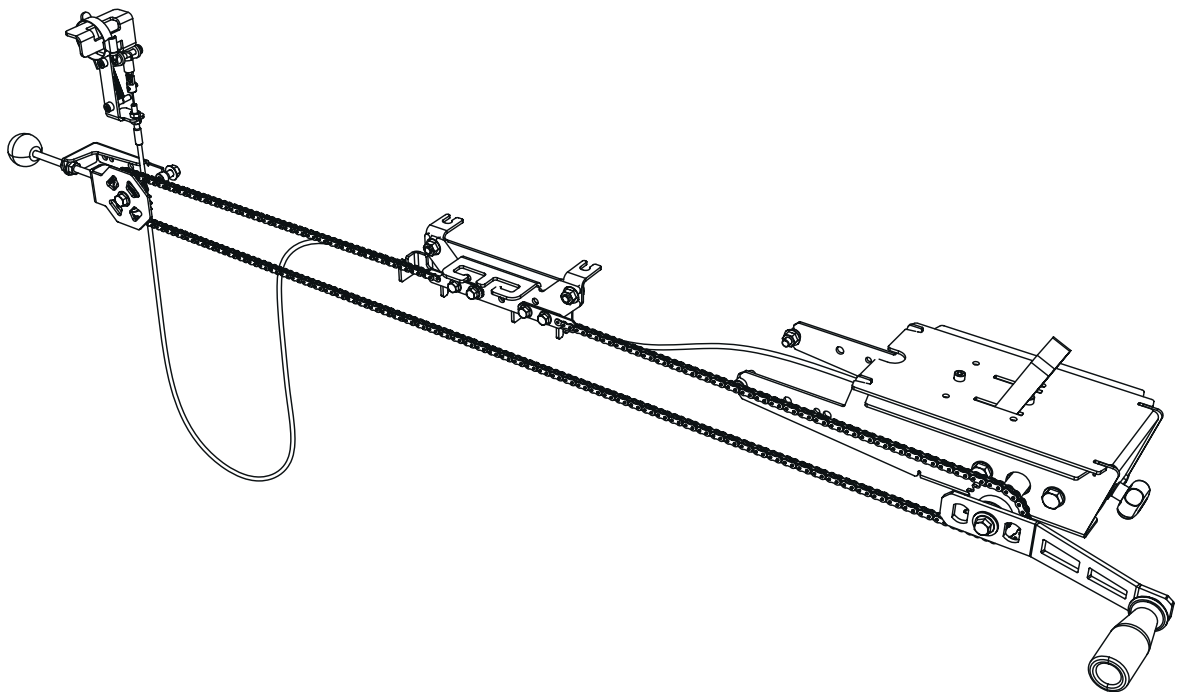









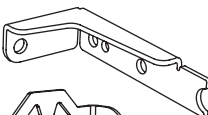
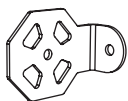

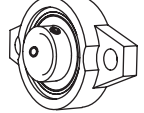
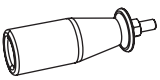

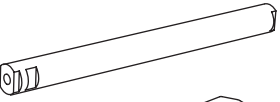

# MOOTTORISAHAN MANUAALINEN ETÄSYÖTÖ

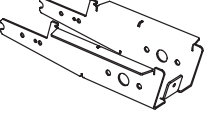
FI

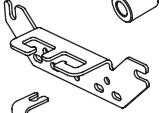
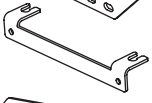
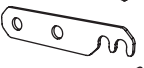

## 01-00696 TOIMITUKSEEN SISÄLTYVÄT OSAT

	_____	1 x	_____	03-02832
	_____	1 x	_____	03-03156
	_____	1 x	_____	04-00561
	_____	1 x	_____	03-03158
	_____	2 x	_____	04-00409
	_____	1 x	_____	DS-00169
	_____	1 x	_____	03-03239
	_____	1 x	_____	03-02819
	_____	1 x	_____	03-02813
	_____	1 x	_____	04-00407
	_____	1 x	_____	DK-00110
	_____	1 x	_____	03-02811
	_____	1 x	_____	03-03159
	_____	1 x	_____	03-02797
	_____	1 x	_____	03-02796
	_____	4 x	_____	03-03157
	_____	1 x	_____	01-00697, 4 m
	_____	1 x	_____	01-00696-skp
	_____	1 x	_____	01-00777-skp

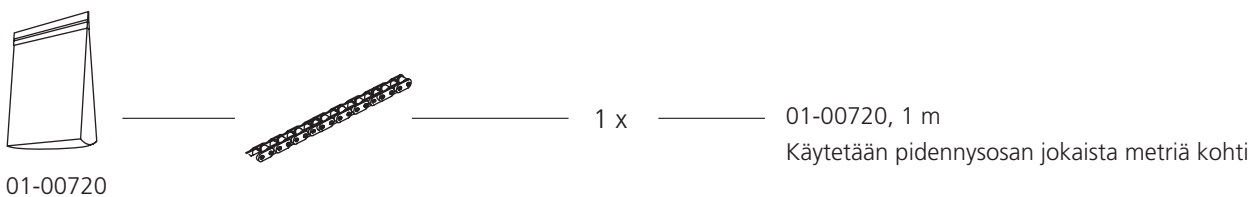
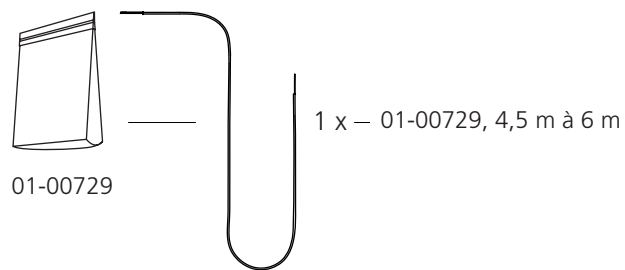
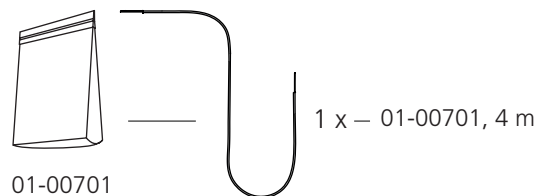
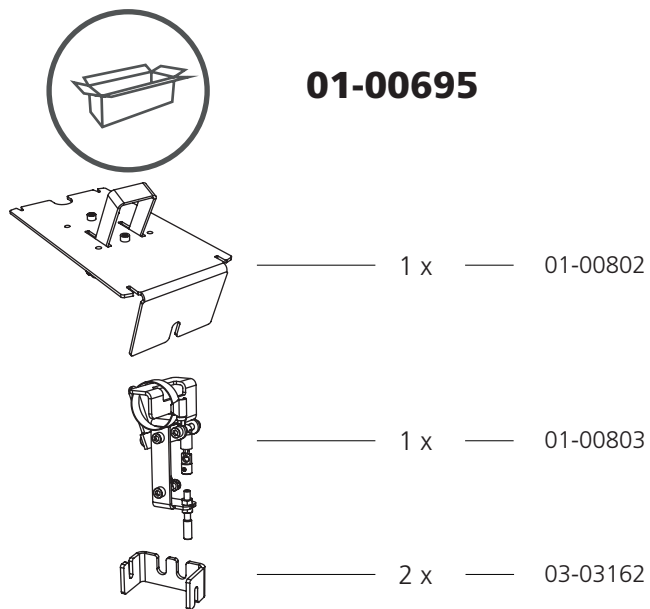
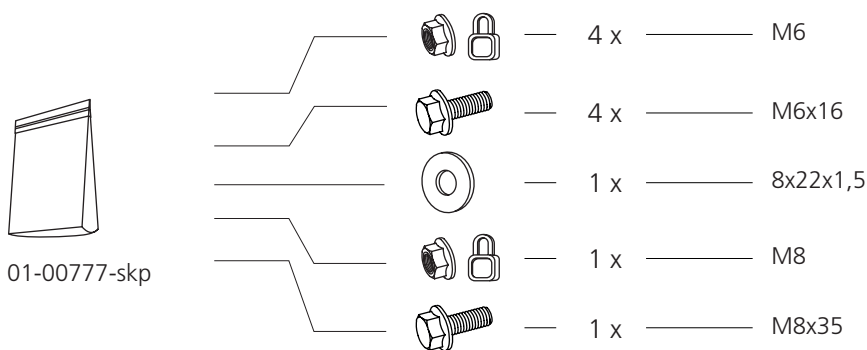
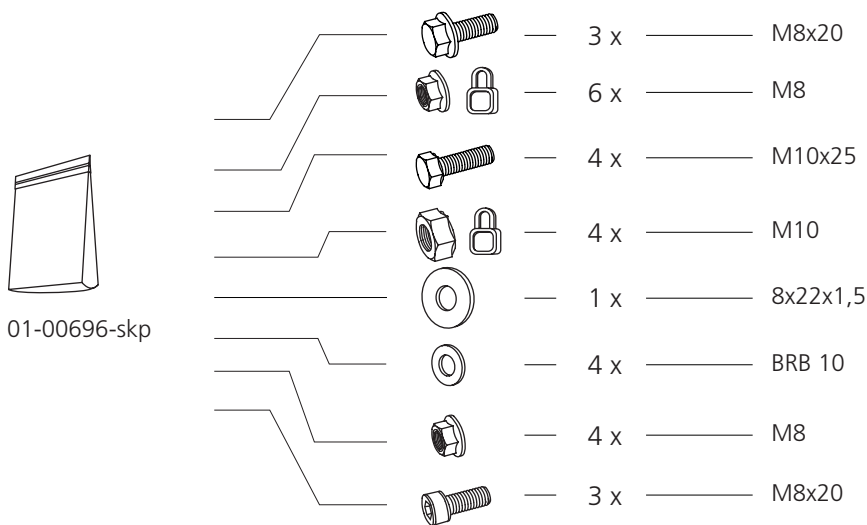



01-00696

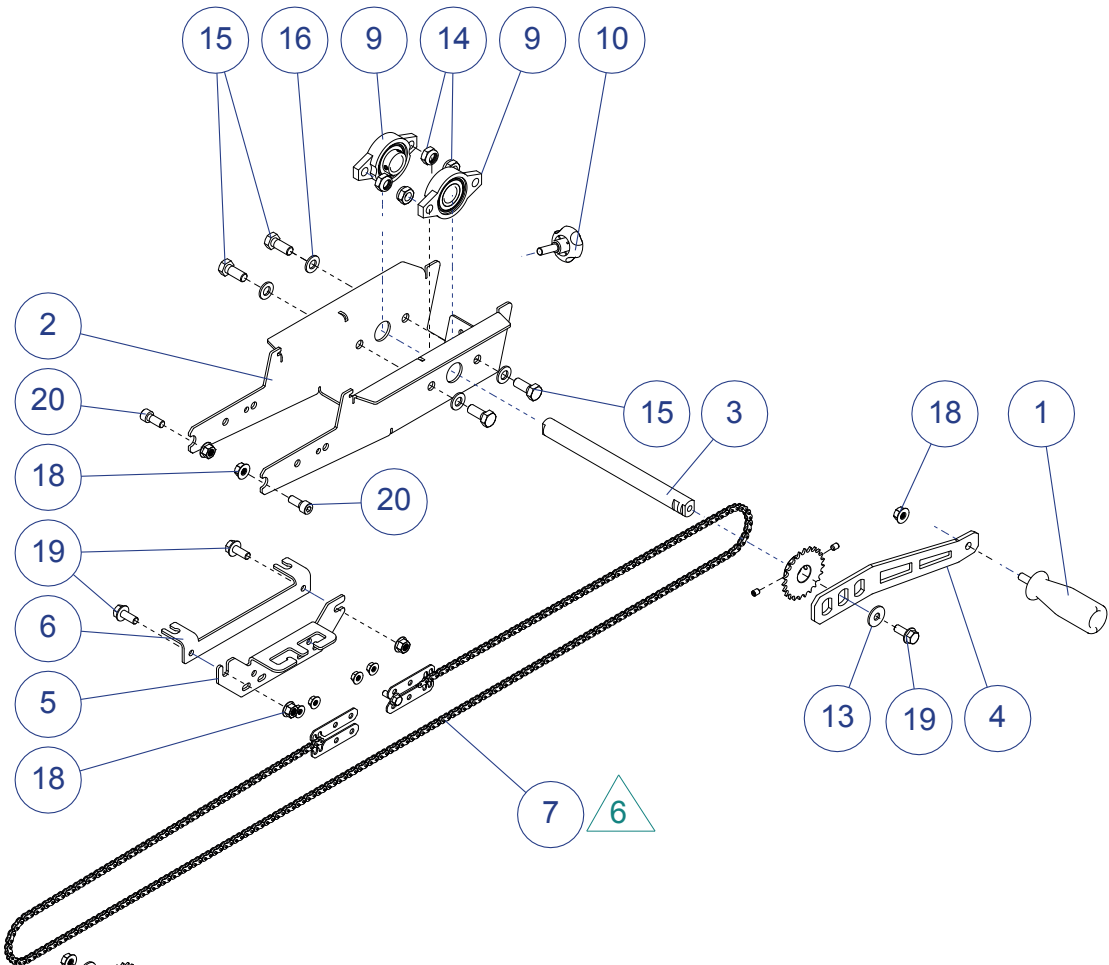

Exploded view

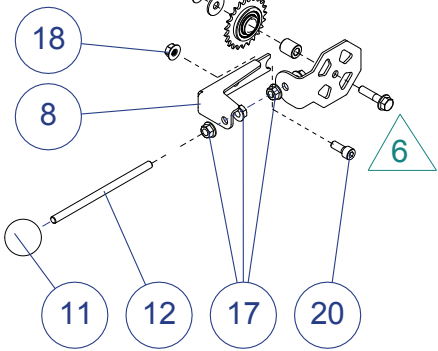

20	MC6S M8x20	3	Allen screw	
19	M6SF M8x20	3	Flange screw M6SF DIN 6921	
18	LM6MF M8 Fzb	6	Nylon lock flange nut Fzb	
17	M6MF M8	4	Flange nut M8 Fzb	
16	BRB 10	4	Washer 10,5x22 t=2 Fzb	
15	M6S M10x25	4	Hex screw M6S Fzb	
14	LM6M M10	4	Hex Nylon Lock Nut Fzb	
13	ISO 4759/3	1	Washer NB 8x22x1,5	
12	03-03239	1	Threaded rod M8x150 8.8 fzb	1
11	DK-00110	1	Endcap WN319 G32-M8	1
10	04-00407	1	Knob M8x25	1
9	04-00409	2	Flanged bearing Ø20 KFL004	1
8	03-02832	1	Turn wheel bracket	1
7	01-00777	1	Manual feed chain kit	4
6	03-02796	1	Bracket	2
5	03-02797	1	Cable & Wire mount	1
4	03-02813	1	Crank handle	1
3	03-02819	1	Crankshaft	1
2	03-02811	1	Chassis	1
1	DS-00169	1	Handle w.out end cap	2
<b>Item no.</b>	<b>Art.no.</b>	<b>Qty.</b>	<b>Description</b>	<b>Issue</b>



01-00777

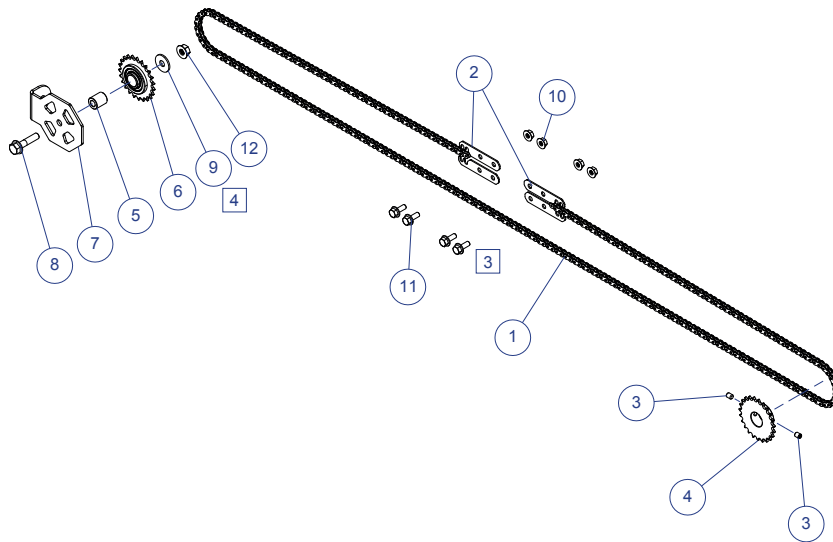

12	LM6MF M8 Fzb	1	Nylon lock flange nut Fzb	
11	M6SF M6x16	4	Flänsskruv M6SF DIN 6921	
10	LM6MF M6	4	Nylon lock flange nut Fzb	
9	ISO 4759/3	1	Washer NB 8x22x1,5	
8	M6SF M8x35	1	Flange screw M6SF DIN 6921	
7	03-03156	1	Turn wheel plate	1
6	04-00561	1	05B-1 Z=23 Tension sprocket	1
5	03-03159	1	Spacer D=15,8x8,1 L=18,5	1
4	03-03158	1	Sprocket 05B-1 z=23 d=20 L=14	1
3	P6SS M6x8	2	Pin screw	
2	03-03157	4	Chainholder	1
1	01-00697	1	Feed Chain (Manual)	1
<b>Item no.</b>	<b>Art.no.</b>	<b>Qty.</b>	<b>Description</b>	<b>Issue</b>

## RUUVIT/MUTTERIT

Seuraavilla sivuilla esitettyjen kiinnitysosien määritelmät.

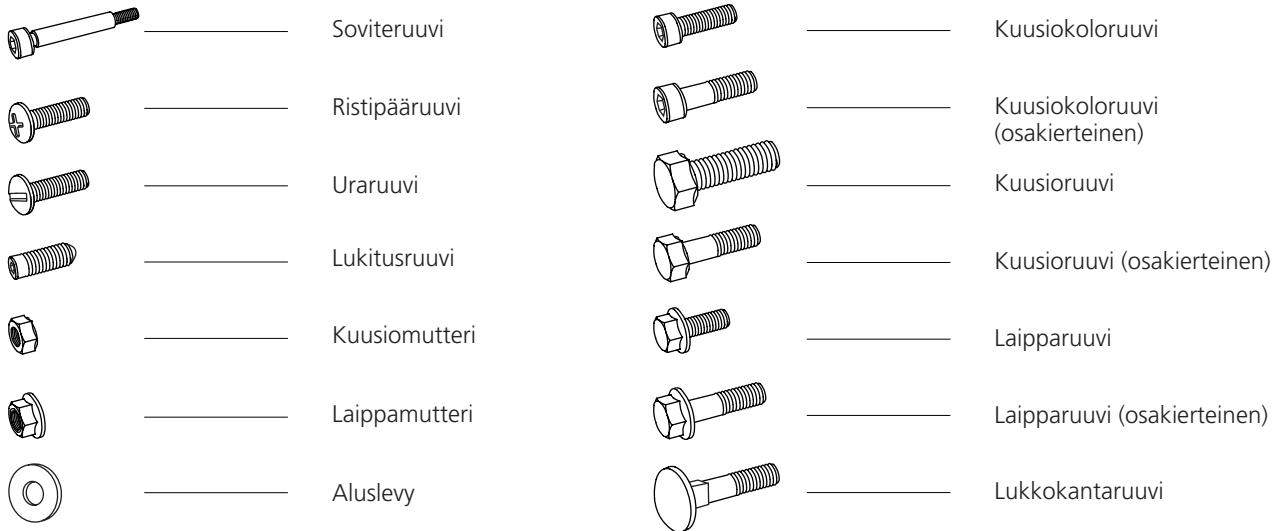

### LISÄSYMBOLIT

Seuraavia symboleja käytetään yllä olevien kuvien yhteydessä osan kuvaamiseksi.



### KOKO/PITUUS

Kiinnitysosien koko ilmoitetaan halkaisijana **(M)** ISO 68-1. Ruuveille ilmoitetaan myös pituusmitta, joka ilmaisee, miten pitkä osa ruuvista uppoaa asennettaessa materiaalin sisään.







<b>(Halkaisija)</b>		<b>(Pituus)</b>
M8	x	20

# ASENNUS





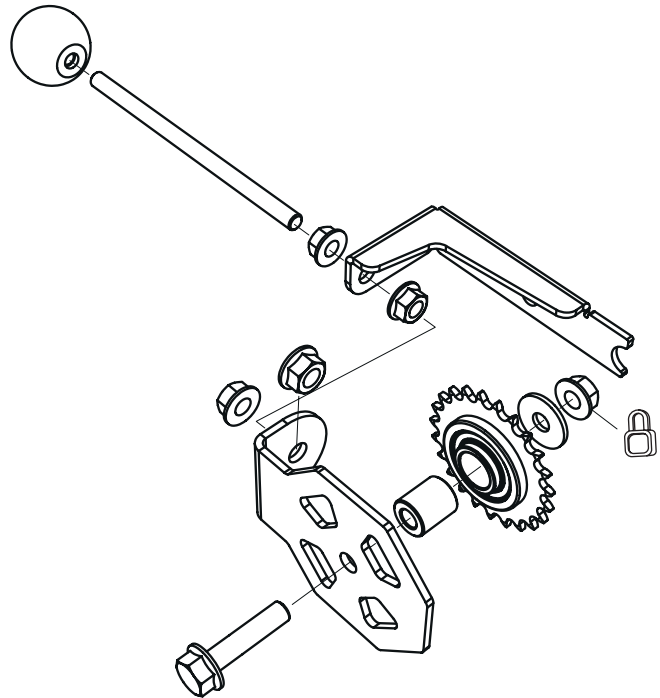

**01-00696**

**1**

-  — 1 x — 8x22x1,5
-  — 1 x — M8x35
-  — 4 x — M8
-  — 1 x — M8
-  — 1 x — 04-00561
-  — 1 x — 03-03159

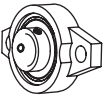



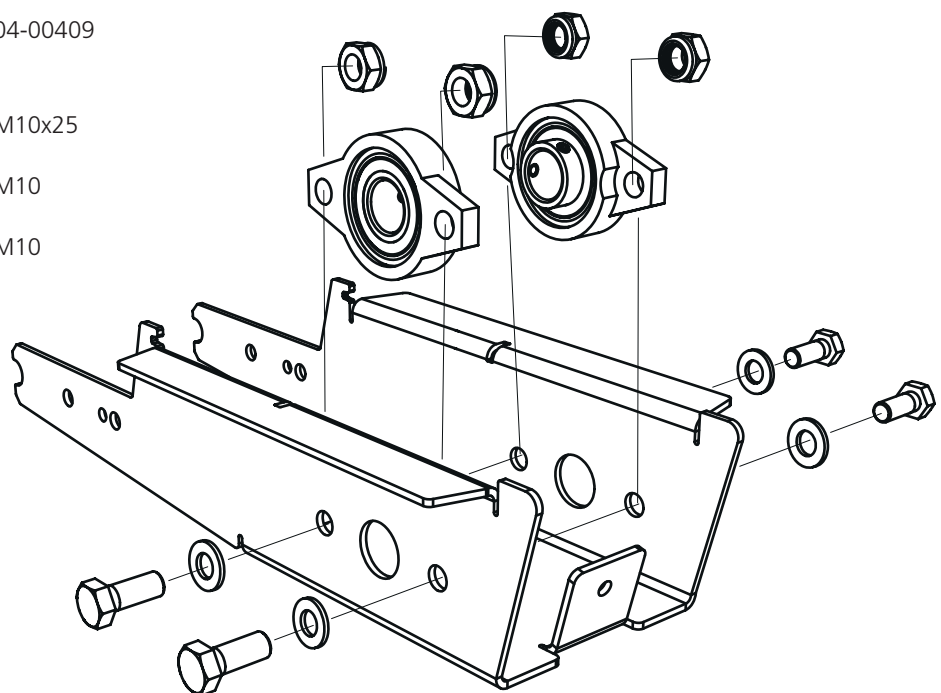

**2**

-  — 2 x — 04-00409
-  — 4 x — M10x25
-  — 4 x — M10
-  — 4 x — M10



**3**

## Kammen kahvan asennus

-  — 1 x — 8x22x1,5
-  — 1 x — M8x20
-  — 1 x — M8
-  — 1 x — 03-03158

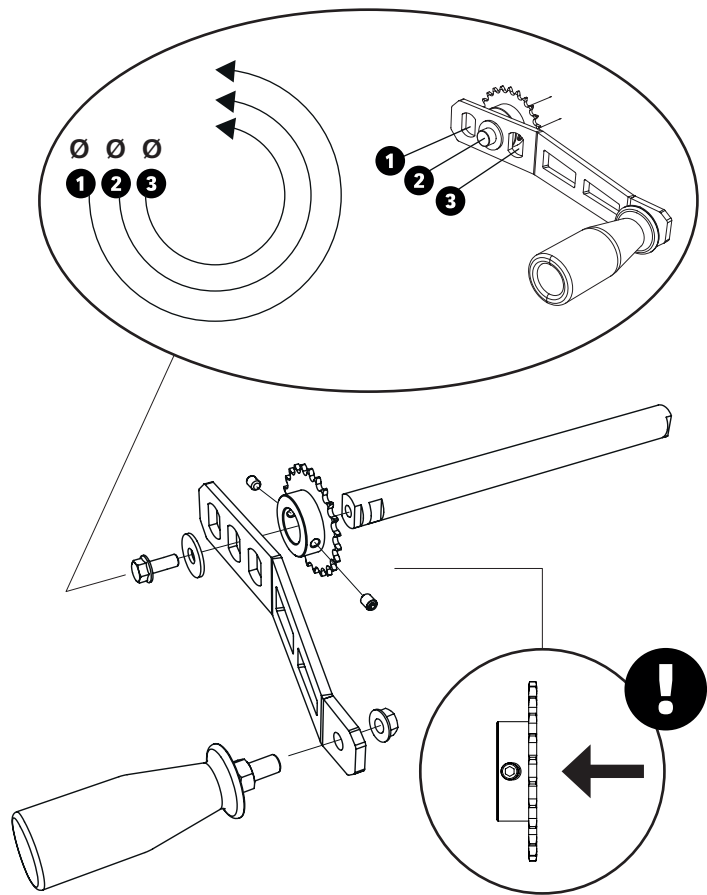

Kammen kahva voidaan asentaa sekä oikealle että vasemmalle puolelle.

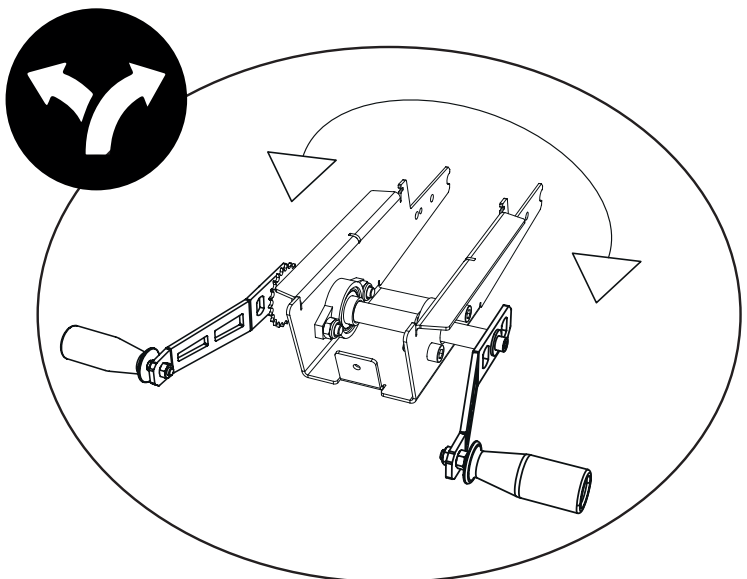



4

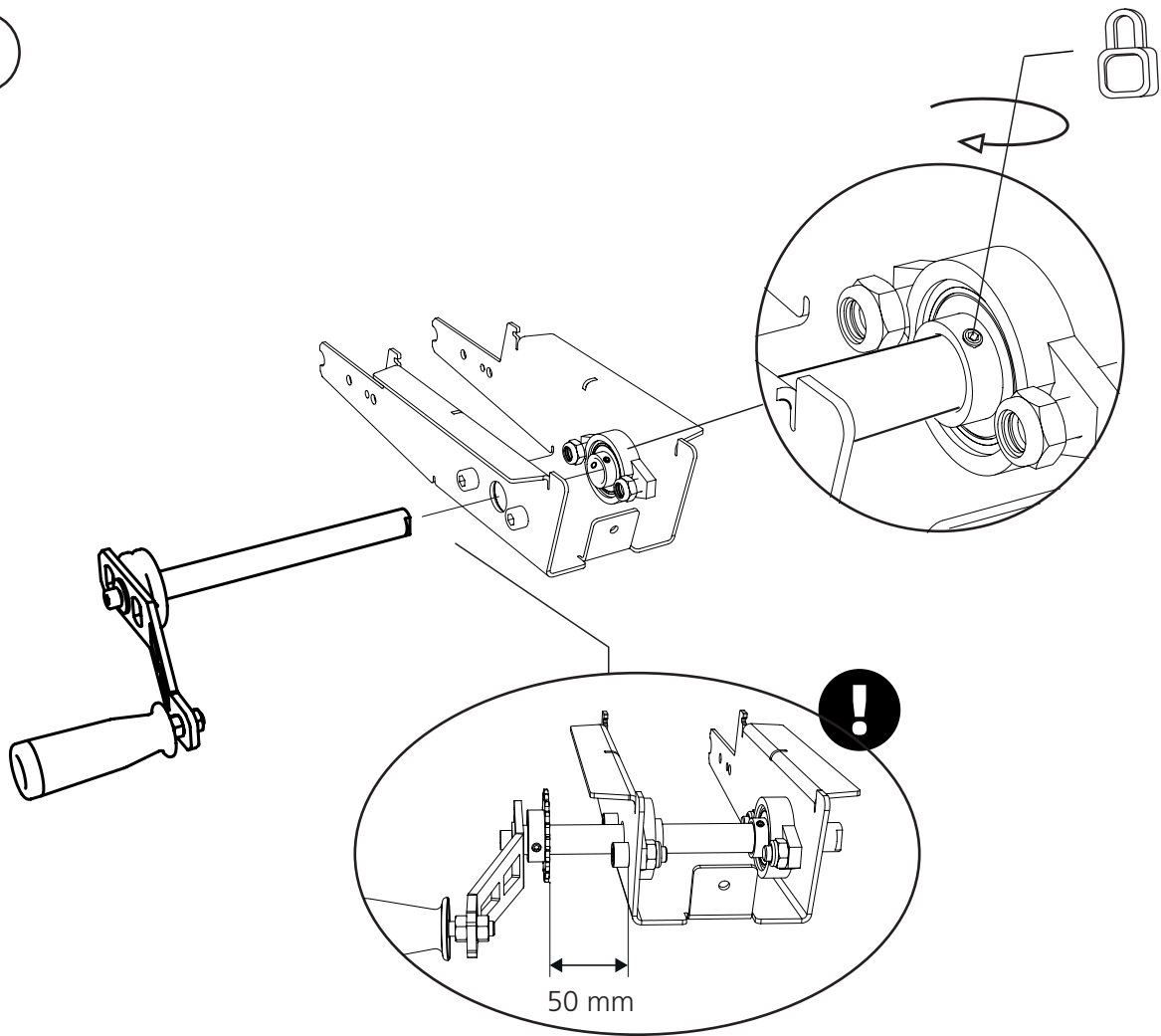

5

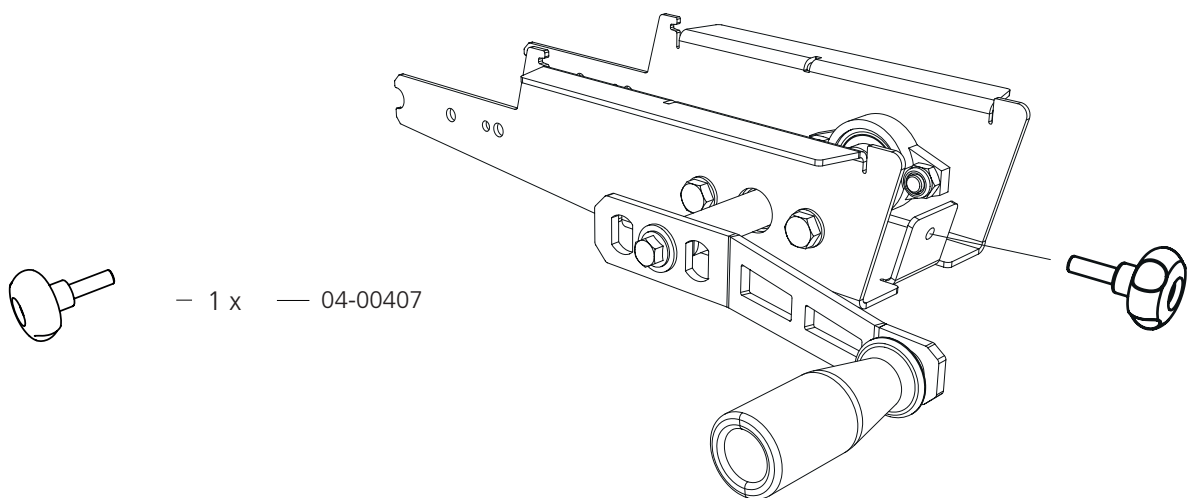

6



— 2 x ————— M8x20



— 2 x ————— M8

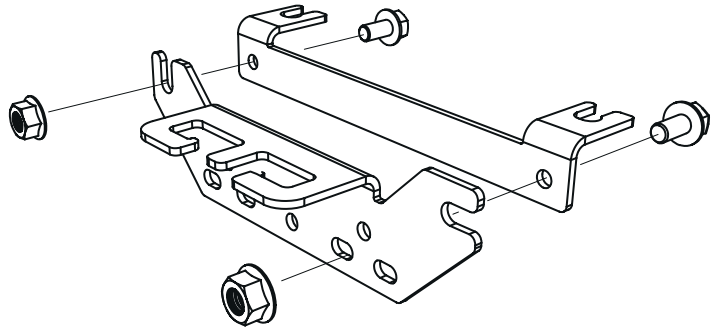

7

Asennuksessa käytetään kelkan ruuviliitosta.



— 2 x ————— M8x35





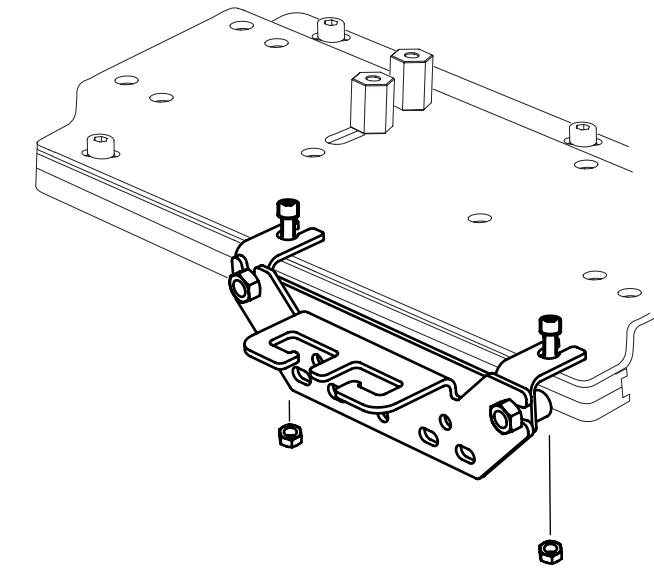

— 2 x ————— M8

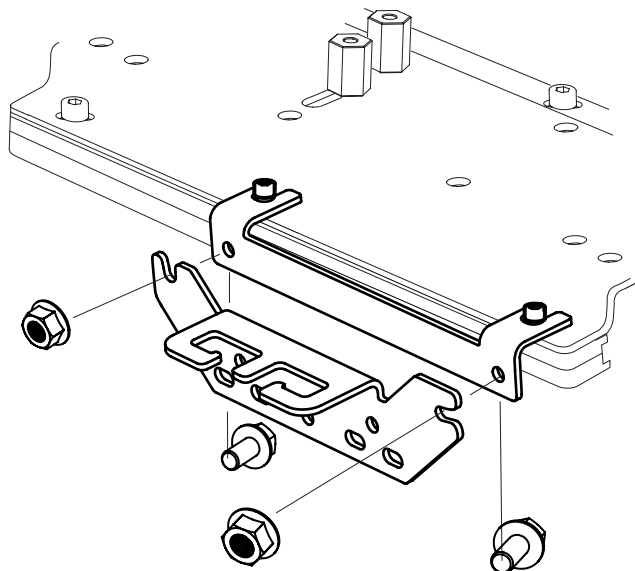

Sahayksikön huollon helpottamiseksi vaijerikiinnike voidaan irrottaa sahakelkasta löysäämättä vaijeria.



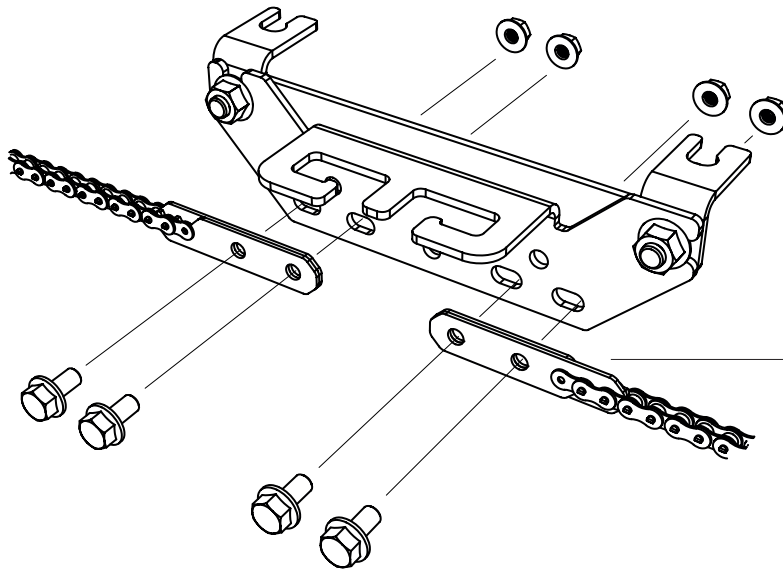
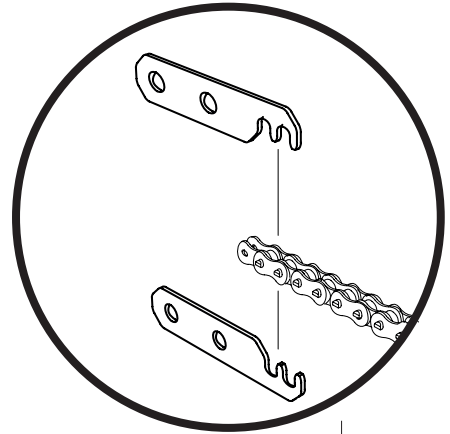

8

-  — 4 x ————— M6x16
-  — 4 x ————— M6
-  — 1 x ————— 01-00697, 4 m
-  — 1 x ————— 01-00720, 1 m  
Käytetään pidennysosan jokaista metriä kohti



9

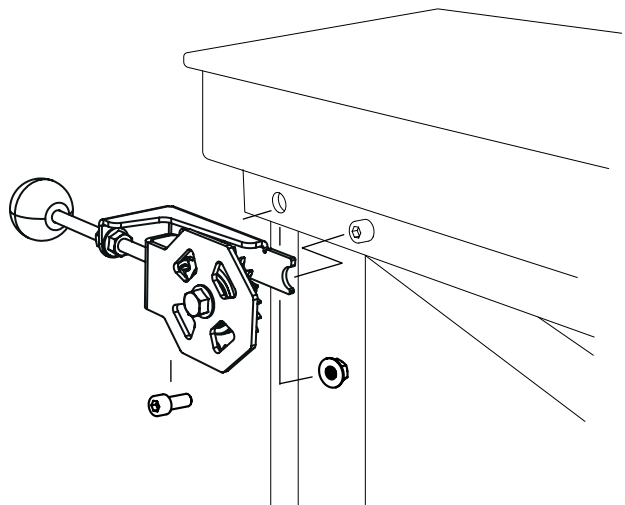

Asennuksessa käytetään osittain palkin ruuviliitosta.

-  — 1 x ————— M8x20
-  — 1 x ————— M8



10

Asennuksessa käytetään osittain palkin ruuviliitosta.

-  — 2 x — M8x20
-  — 2 x — M8

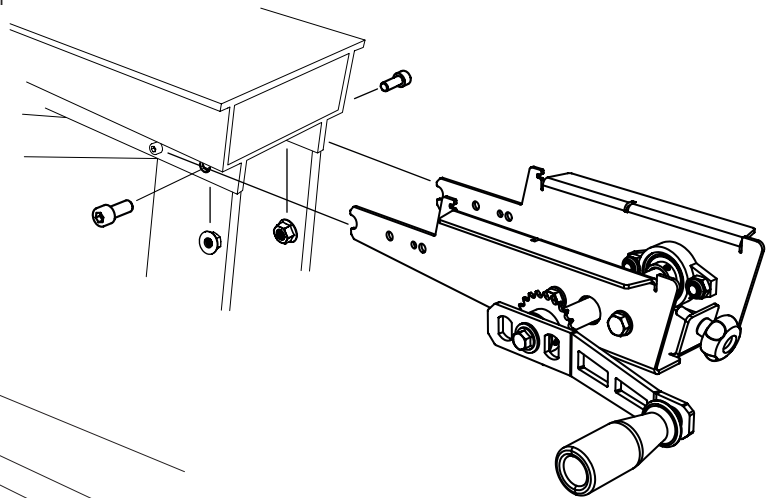

11

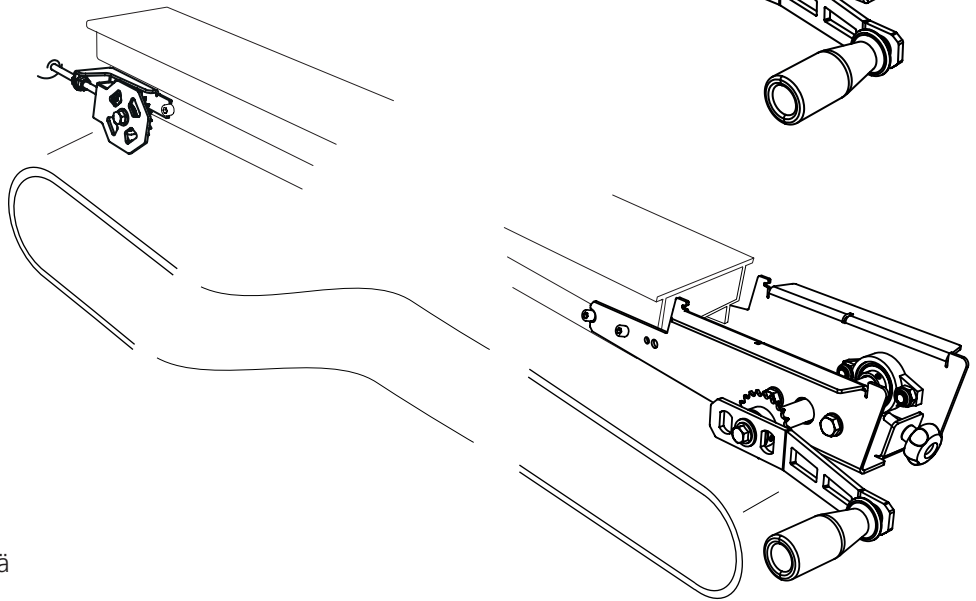
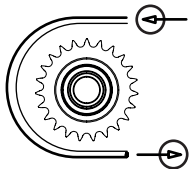

12

Kiristä käyttöketju siten, että ketjujen välissä on 6–7 cm.

Kireyden säätämiseksi kiristysmekanismin laippamutteria on löysättävä.

Varmista säätämisen jälkeen, että laippamutteri kiristetään uudelleen.

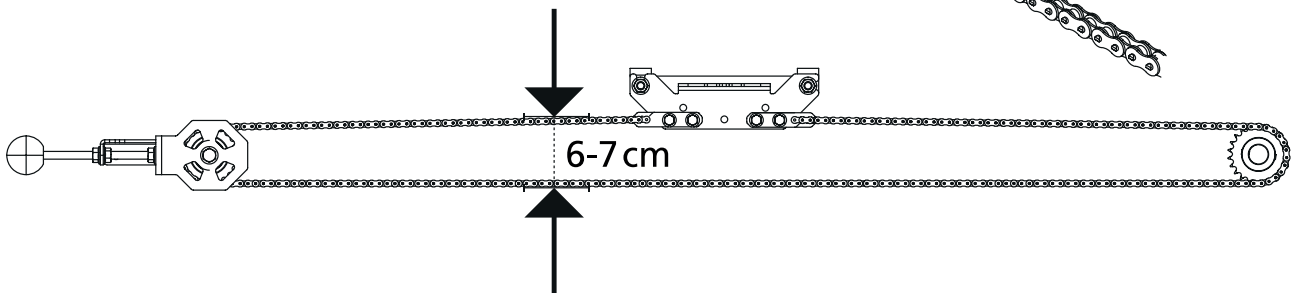
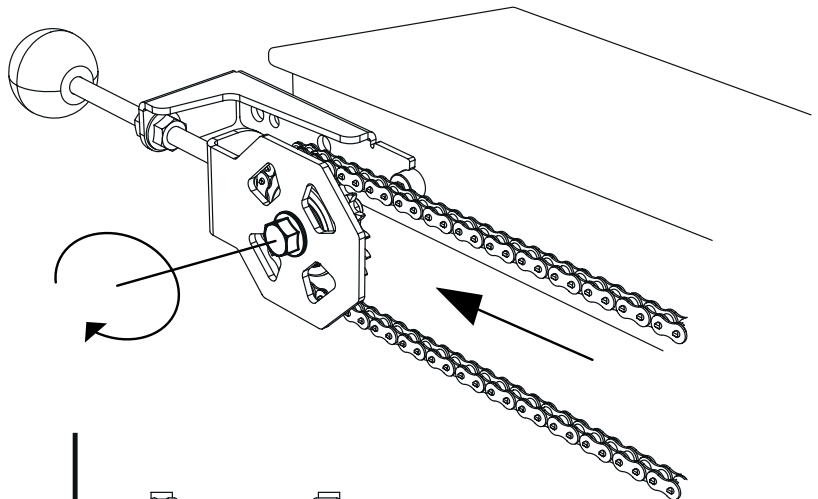

13

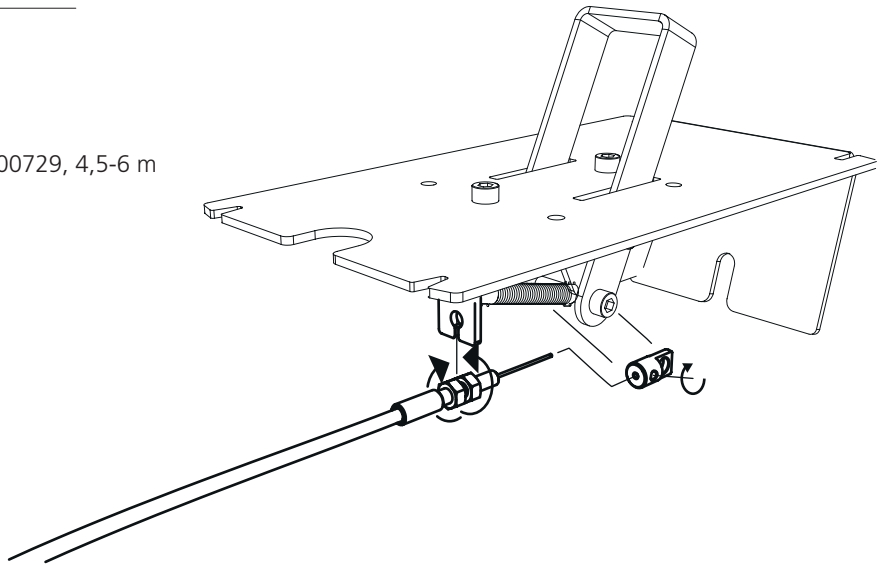
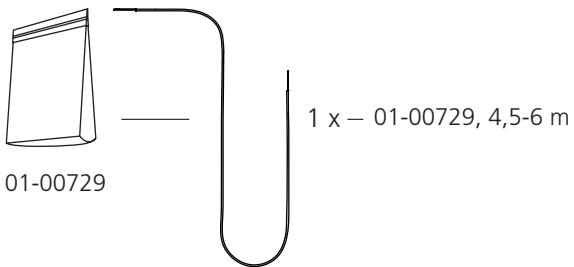
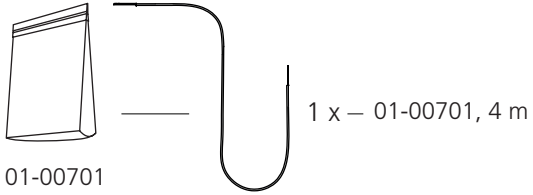

14

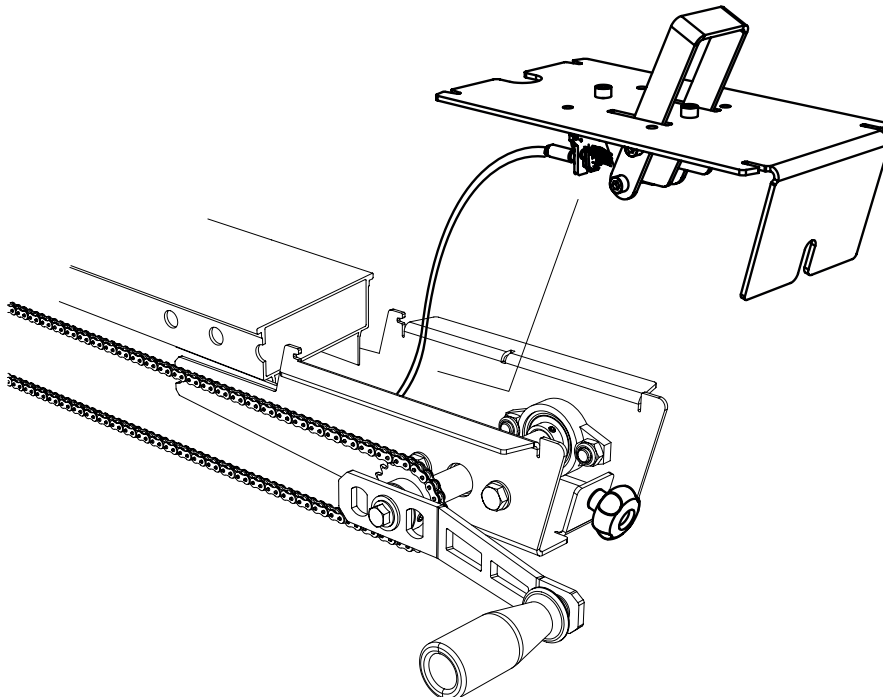

15

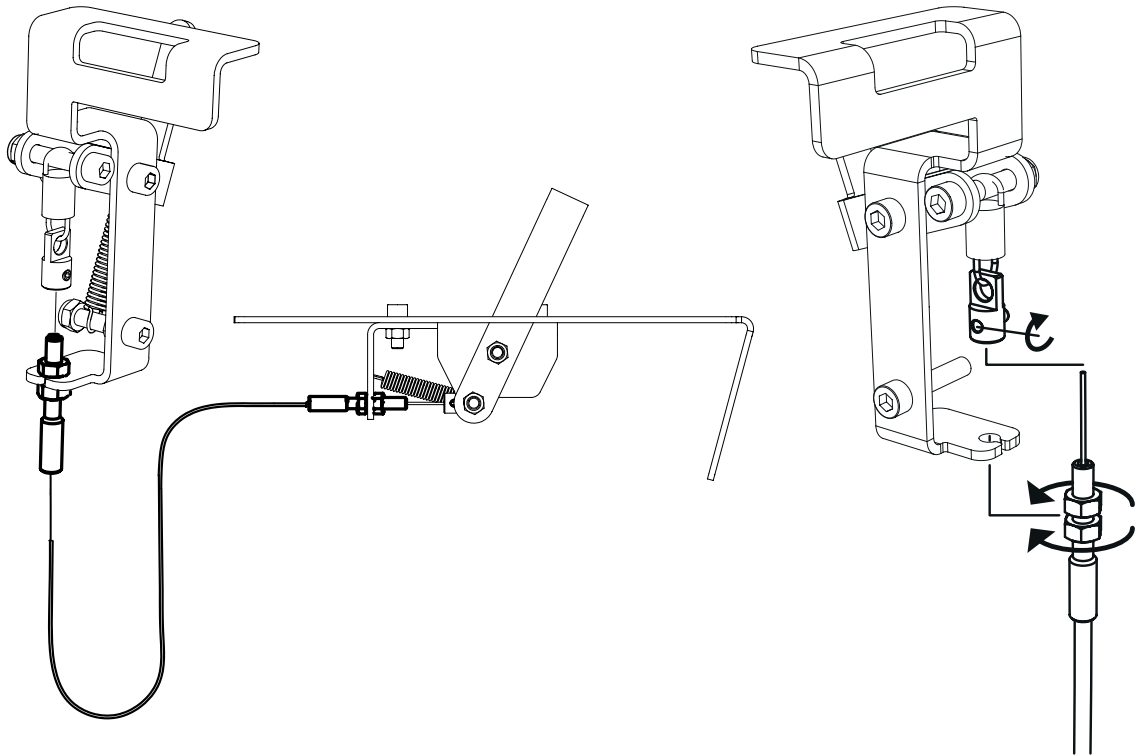

16

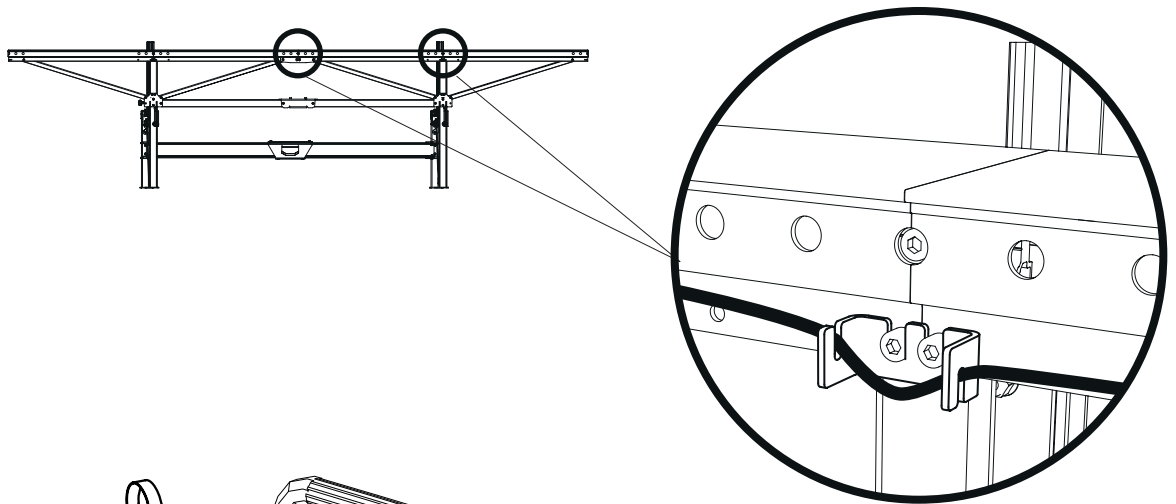

17

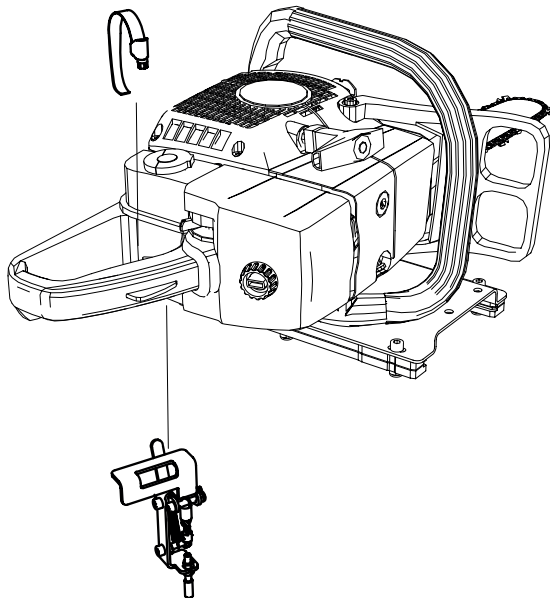

18

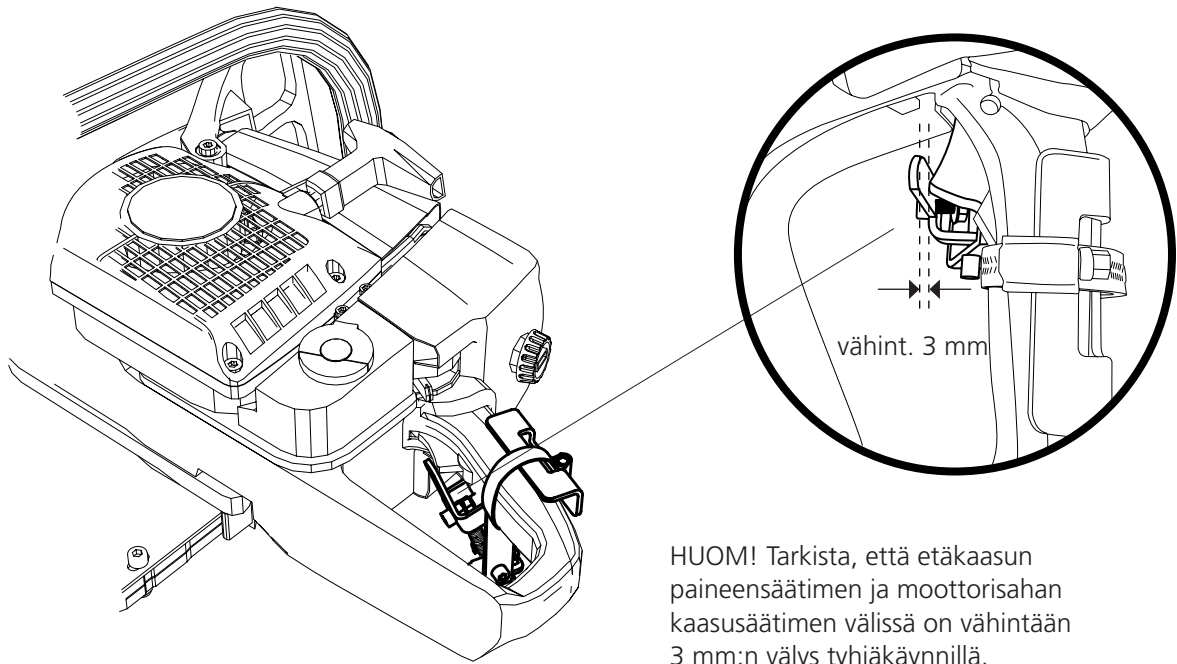

HUOM! Tarkista, että etäkaasun  
paineensäätimen ja moottorisahan  
kaasusäätimen välissä on vähintään  
3 mm:n välys tyhjäkäynnillä.

19

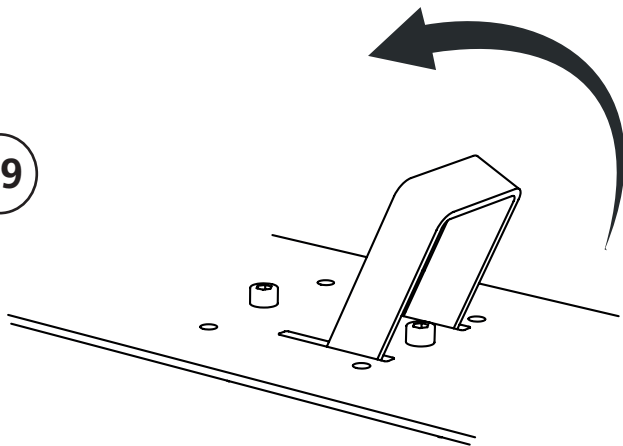

20

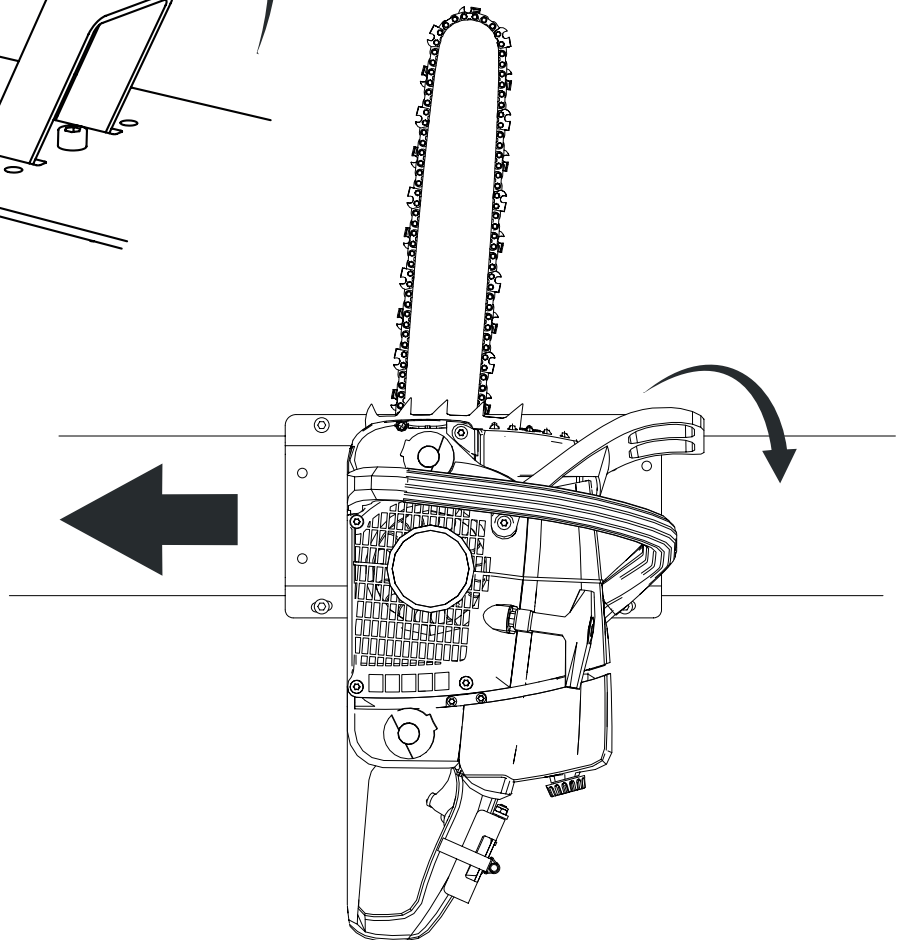



## Vaatimustenmukaisuus- vakuutus

Direktiivin 2006/42/EY liitteen 2A mukaisesti

Logosol AB  
Fiskaregatan 2  
871 33 Härnösand

vakuuttaa täten, että **Logosol manuaalinen etäsyöttö moottorisahalle**

on valmistettu täyttämään vaatimukset, jotka on esitetty konedirektiivissä 2006/42/EY

sekä että se on valmistettu täyttämään seuraavat yhdenmukaistetut standardit:  
EN ISO 12100:2010

Toimitusjohtaja Fredrik Forssberg vastaa teknisestä dokumentoinnista.

**Härnösand 27.10.2022**

**Fredrik Forssberg, toimitusjohtaja**

# LOGOSOL

Fiskaregatan 2, S-871 33 Härnösand, Ruotsi  
Puh. +46 611 18285 | info@logosol.fi | www.logosol.fi