

USER MANUAL

ORIGINAL USER MANUAL.

SKU: 0458-395-5431

REV: 2

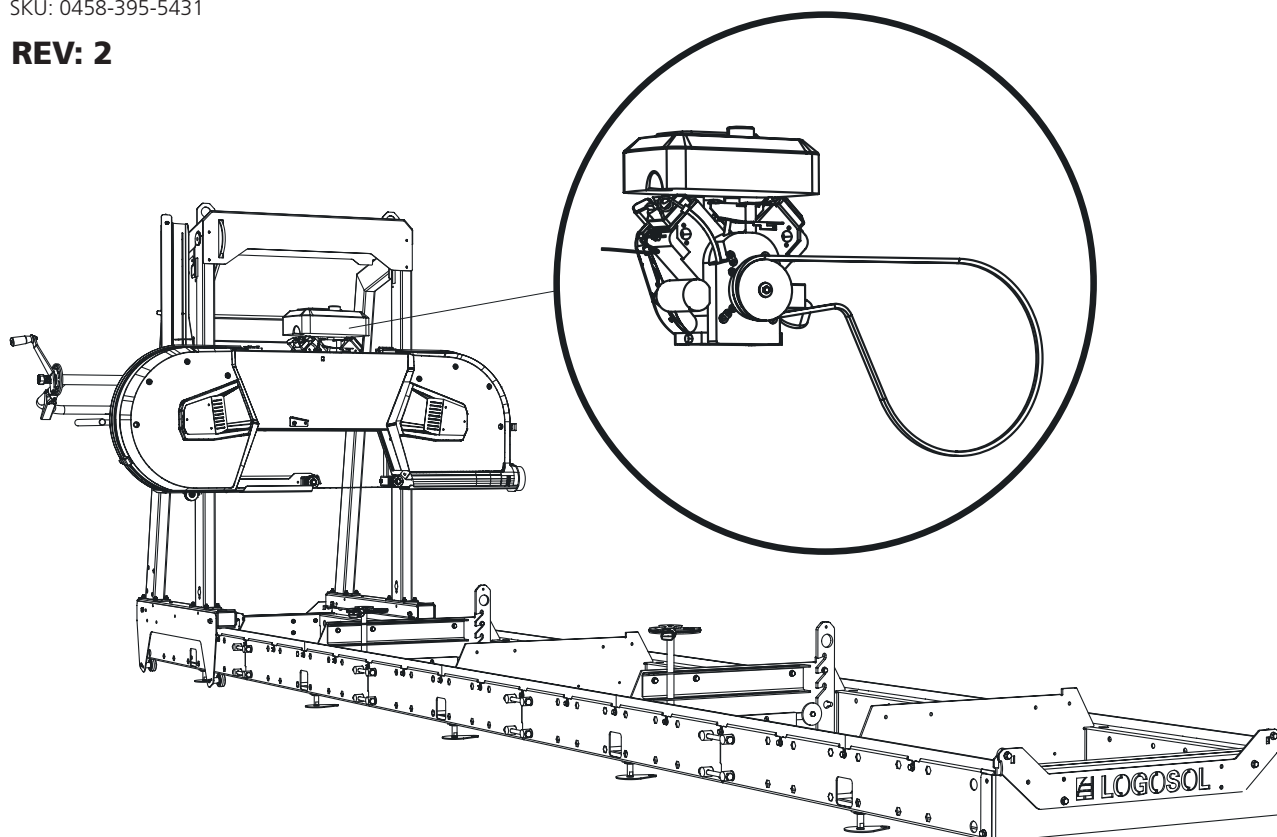

15 HP PETROL ENGINE LONCIN

This manual describes installation of the petrol engine for the Logosol band sawmill.

Please see the user manual for your band sawmill for information on assembly, settings and safety instructions.



Read through the user manual carefully and make sure you understand its contents before using the saw.



8200-000-0066
15 hp petrol engine
Loncin

8200-000-0068
Accessory pack, 15 hp
Loncin



FINAL SAW HEAD ASSEMBLY, 15 HP LONCIN



Read through all the set-up instructions before starting to set up, then follow the instructions step by step as you work.

1

Numbering for installation sequence



After assembly, follow the instructions under *Setup sequence* in the sawmill manual to complete setup before starting the machine.

1

Smart set

These assembly operations (1–2) must not be performed if the machine is to be fitted with Smart Set (see Smart Set manual).
Go to step 3.



1 x – 8000-001-6054



1 x – 8000-001-6057



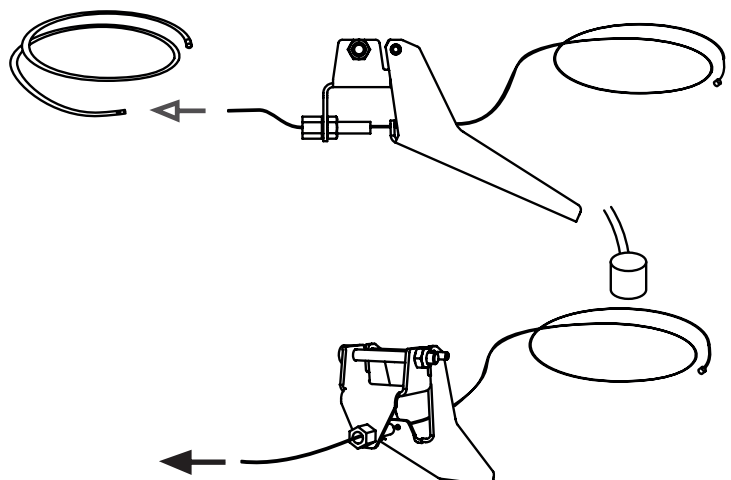

1 x – 8000-001-6060

2



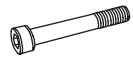
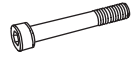

2

Fit the handle on the handle tube.
If this handle is fitted:
Cut the wire housing to 1600 mm.

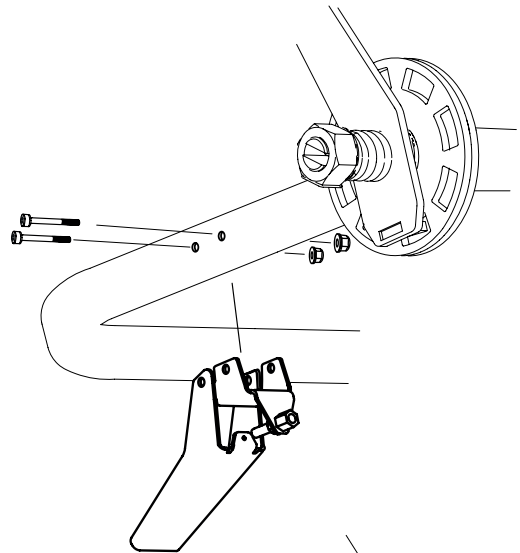
-  1 x – M6x50
-  1 x – M5x50
-  1 x – M6
-  1 x – M5

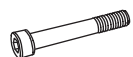
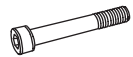

2

-  1 x – M6x50
-  1 x – M5x50
-  1 x – M6
-  1 x – M5

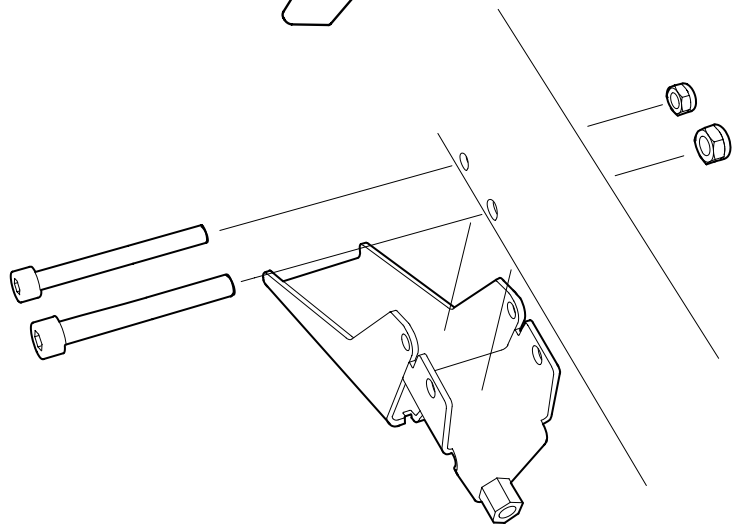

3

Pull the wire and wire housing into the handle as illustrated. If this handle is installed:
The wire housing = 2900 mm.

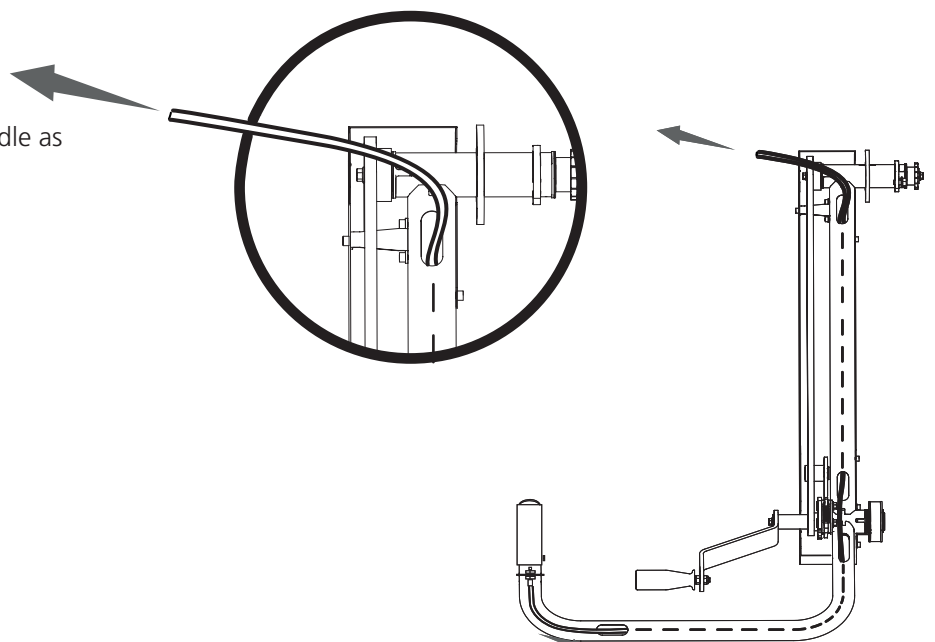

⚠ WARNING! Heavy! Risk of injury.

! Two people are always required to help with heavy lifting.



⚠ WARNING! Risk of entrapment.

! Wear protective gloves and handle the engine carefully when placing it on the engine shelf.

INSTALLATION: ENGINE AND THROTTLE CABLE

The engine has to be installed on the engine shelf and secured using the fastening screws. The centrifugal clutch has to be fitted, and the drive belt and throttle cable also have to be fitted on the sawmill. Follow the assembly instructions, then run through the setup sequence for the machine when assembly is complete.

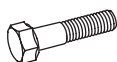
4

-  4 x – M10x40
-  4 x – M10
-  4 x – SKB 11x3,5x2

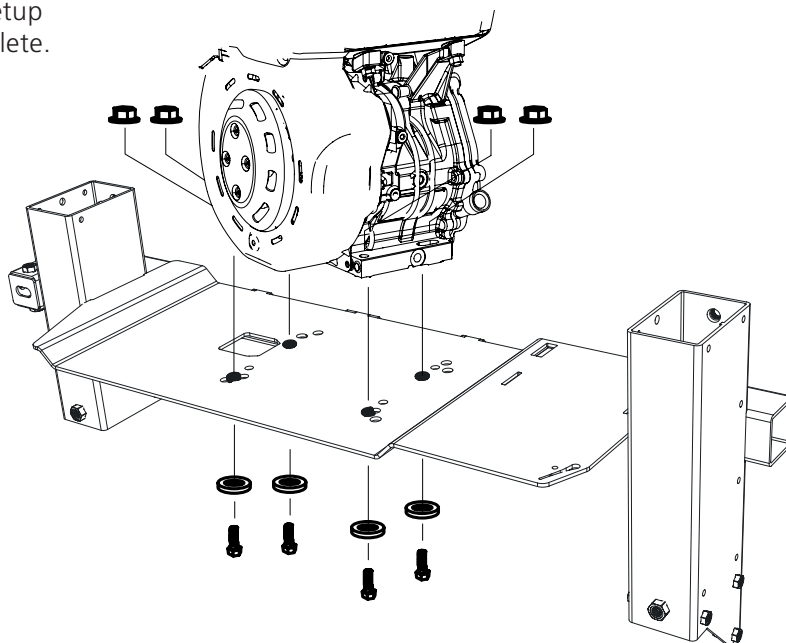

Top view:

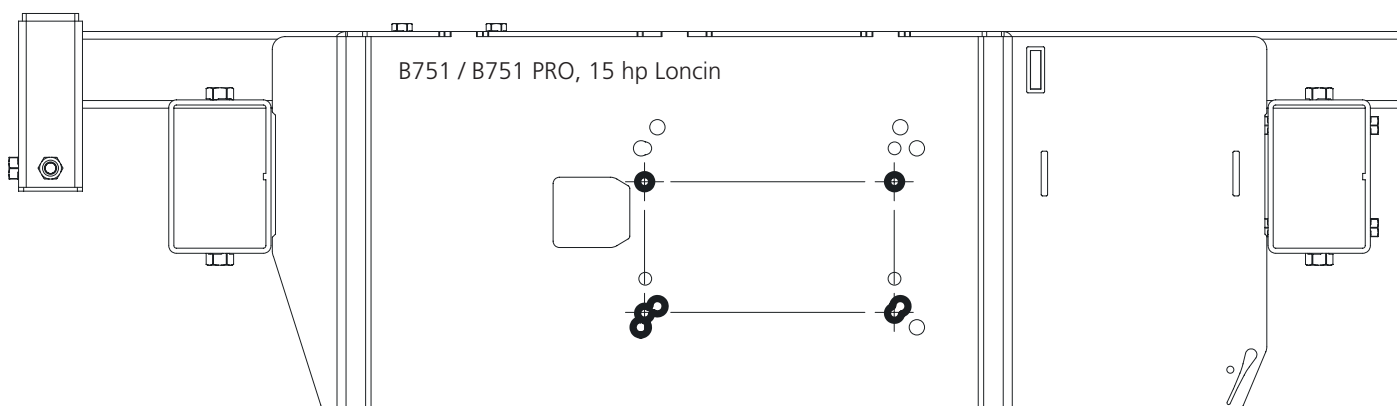

- 5 Trä på drivremmen runt det drivande hjulet och över spännaren.

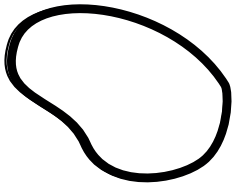

1 x - 9020-011-0091

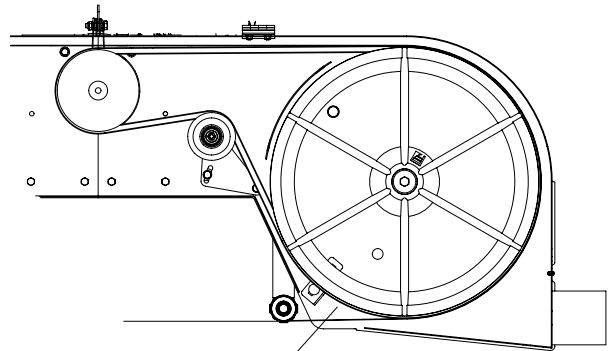

- 6

-  1 x - 9021-014-0003
-  1 x - 3/8UNFx32
-  1 x - SRKB 11x35x2
-  4 x - 03-02448
-  1 x - 03-02053

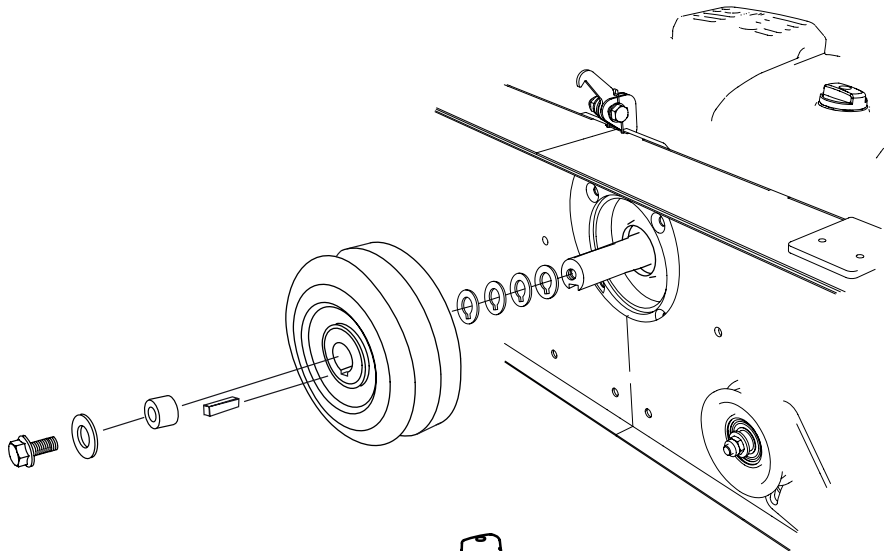

- 7

Fitting the throttle cable: Start by removing the airbox filter and the lower part of the airbox.

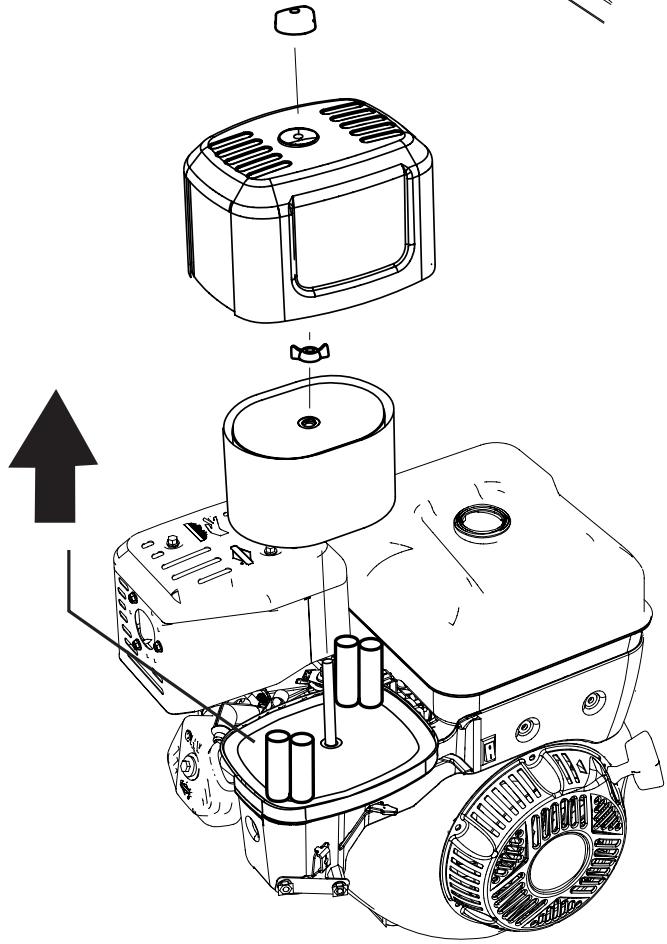

WARNING! Risk of serious injury.

Before adjusting the throttle cable tension on the engine: Turn the ignition to OFF and close the fuel valve.

Always start the machine from the operator's station. Always turn off the machine before adjusting the tension of the throttle cable on the engine side.

WARNING! Risk of burn injuries. The engine and its silencer become very hot during operation and after the engine has been shut down.

Allow the engine and silencer to cool before servicing or performing maintenance on the machine.

8 THROTTLE ADJUSTMENT

- Start by adjusting the throttle cable at the throttle handle so that you have equal adjustment travel in both directions **(1)**
- Attach the other end of the cable housing to the clamp on the engine **(2)**
- Then release the nut holding the throttle control **(3)** in place.
- Screw the cable into the nipple **(4)**. Make sure that the throttle is in the neutral/unaffected position when doing this.
- Check that you have 1 to 3 mm of clearance in the throttle handle, and that the cable moves freely. Adjust the cable tension at the throttle handle **(1)**, if necessary
- Start the engine and check that it is idling and that the saw blade does not move while the throttle handle is in idle position. Adjust the cable tension at the throttle handle **(1)**, if necessary
- Secure the adjustment using the locking nuts **(5)**

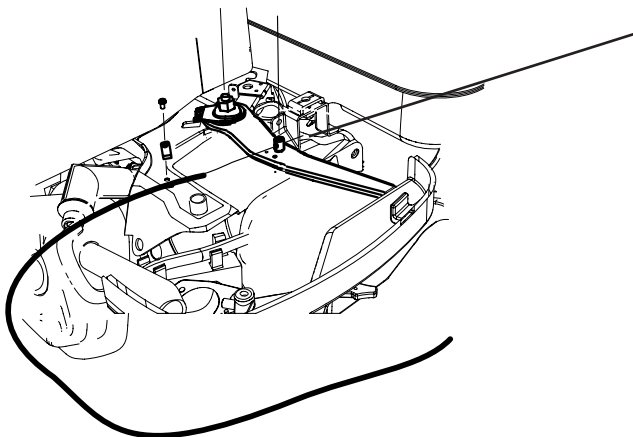
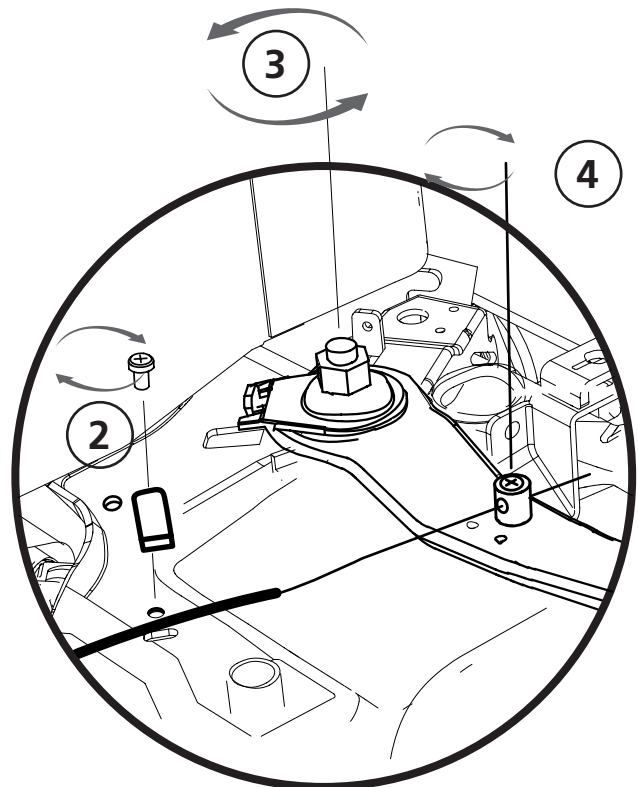
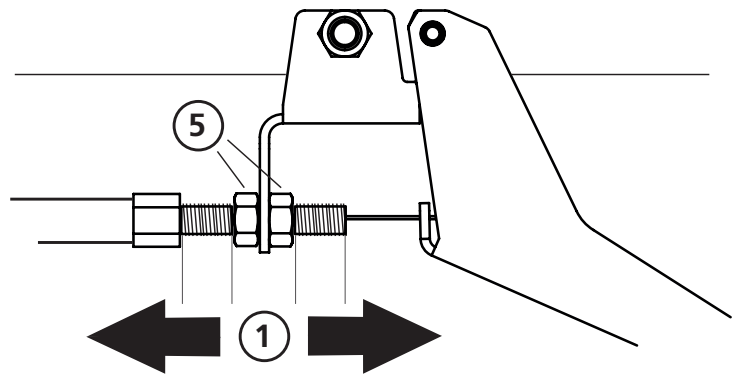

! **WARNING!** Risk of serious injury.

! The hinge switch for the machine has to be fitted before commissioning the machine.

! Always switch off the machine from the operator's position before working on the saw head.

! **WARNING!** Risk of burn injuries. The engine and its silencer become very hot during operation and after the engine has been shut down.

! Allow the engine and silencer to cool before servicing or performing maintenance on the machine.

9

 2 x – M6x25

 2 x – M6x30

 1 x – 03-01997
10mm

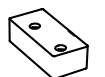
 1 x – 03-02080
12mm

 2 x – 03-02182

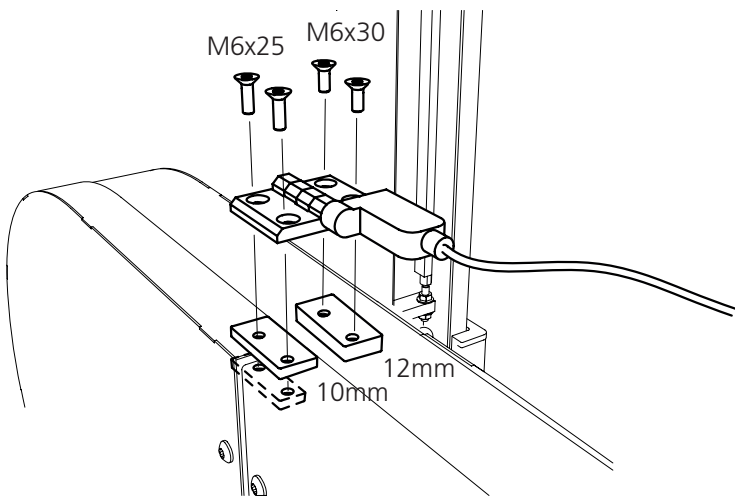

10

1. Mount the voltage regulator onto the battery box.
2. Then, connect the red cable with the fuse holder to the solenoid.
3. Then connect the cable between the battery's positive terminal and the solenoid.
4. Then, complete the assembly by connecting the cable between the negative terminal of the battery and the engine chassis.

 2 x – M6x25

 4 x – M6

 2 x – M6x20

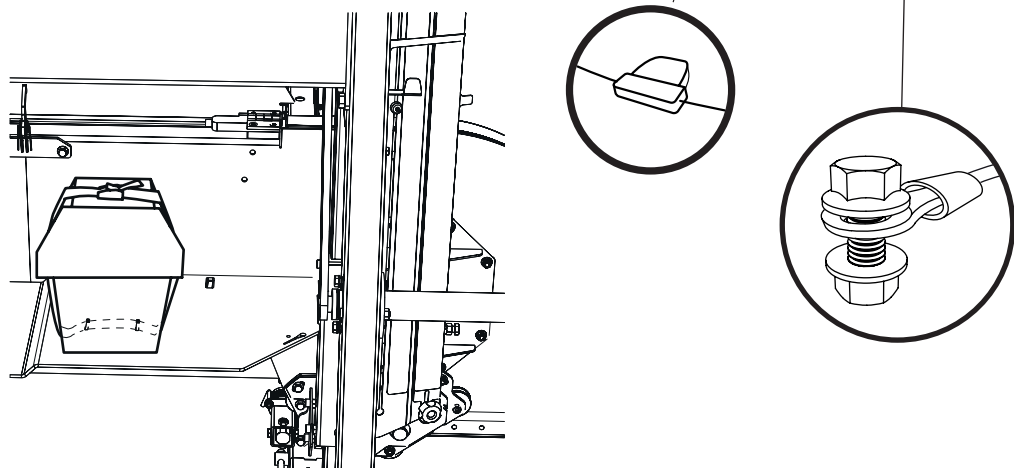
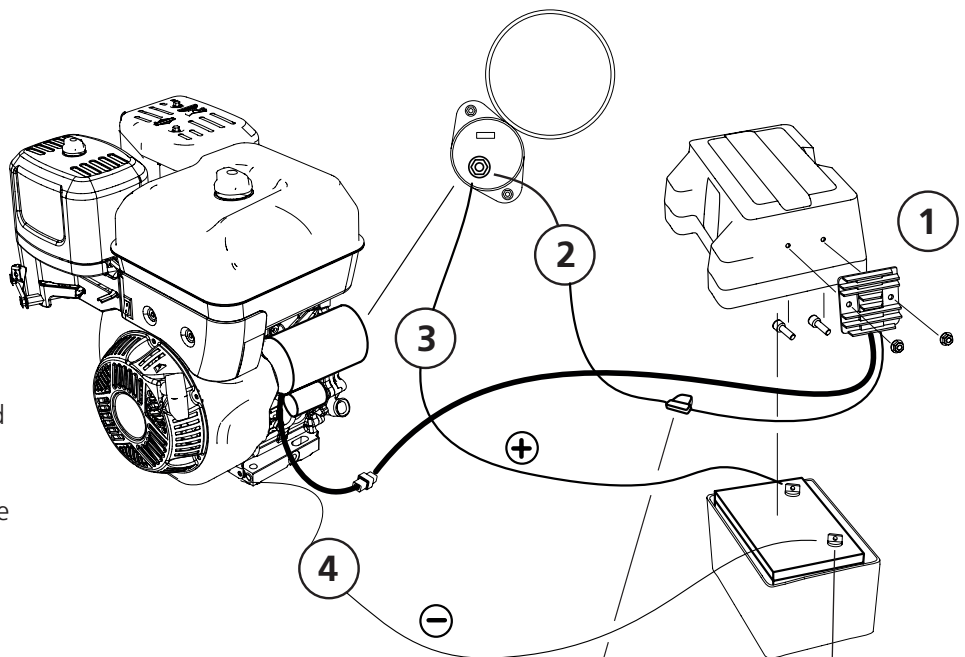

The battery is placed in the protective box and secured using a strap as illustrated.

11

1. Connect the safety switch. The plug must be connected to the severable connector emerging out of the cable assembly.
2. Then plug in the lengthening joint and connect the switch. Then, couple the ring cable lug to the engine chassis.

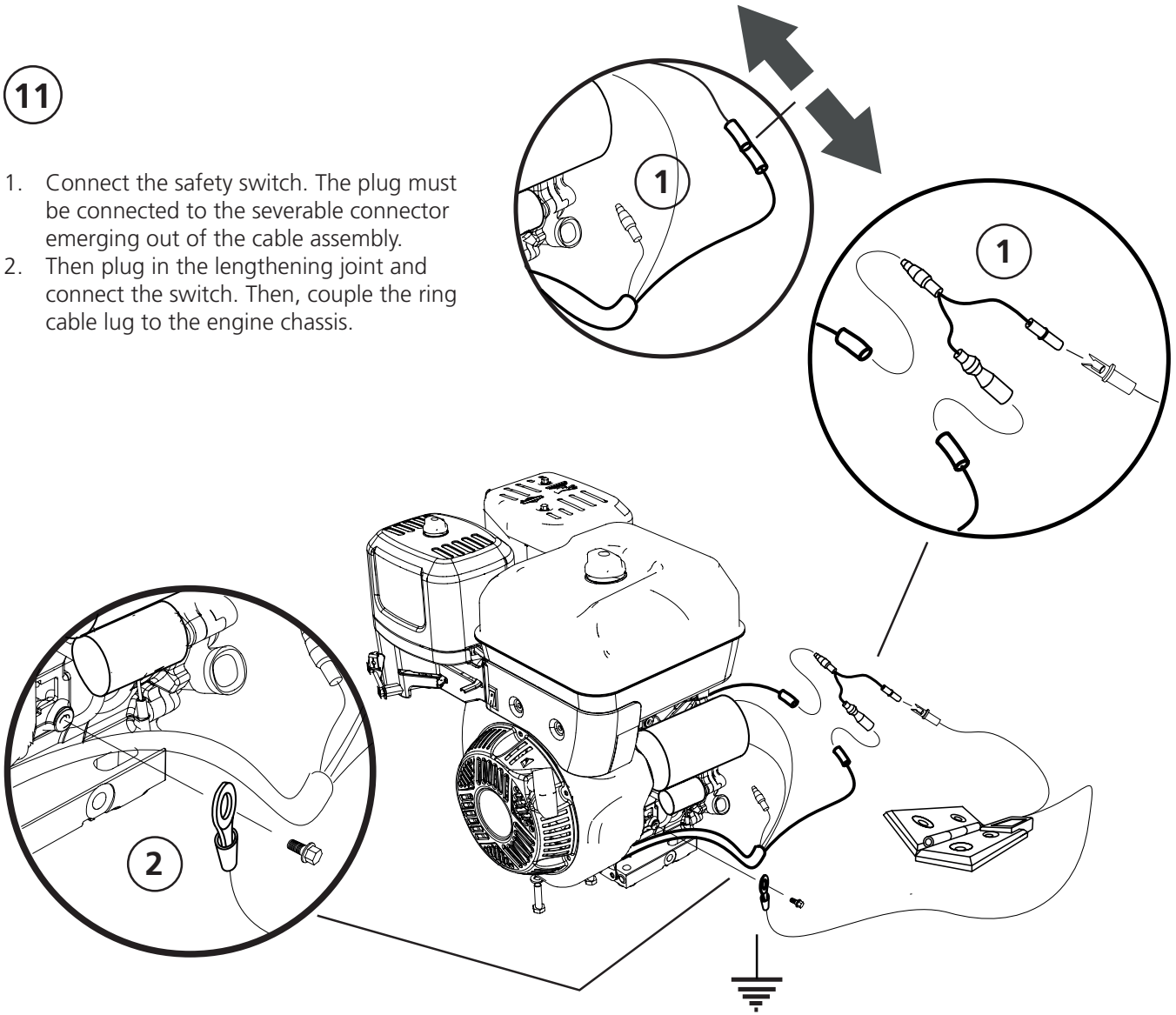

SAFETY SWITCH WIRING DIAGRAM

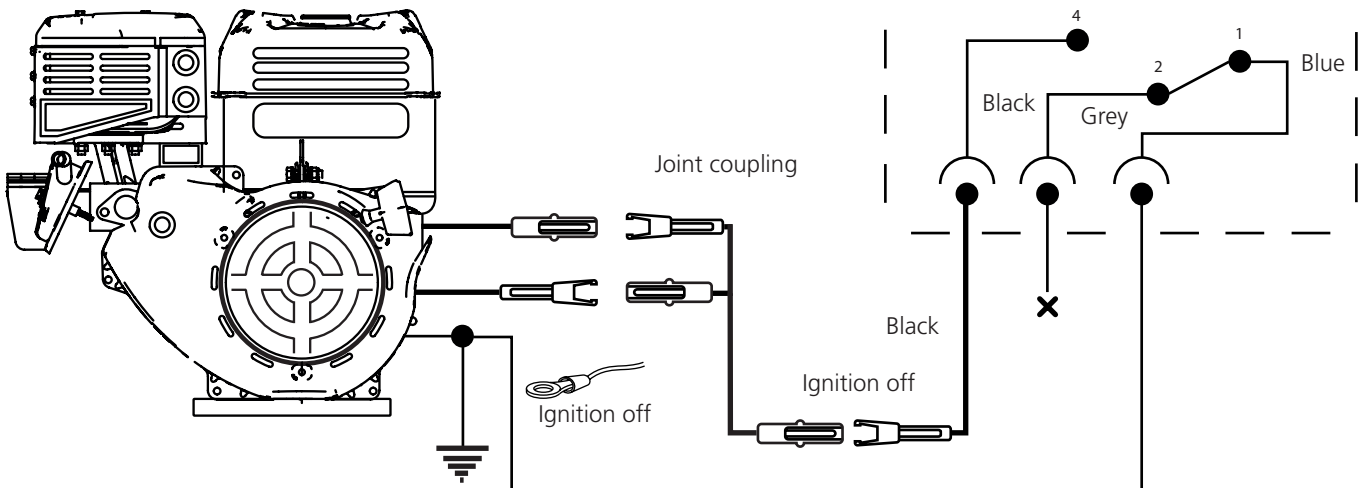



Well done!

Now you have finished installing the engine, go back to the manual for your band sawmill and carry on with the setup sequence, starting at the point as indicated in the instructions below.

SETUP SEQUENCE



Read through all the set-up instructions before starting to set up, then follow the instructions step by step as you work.



IMPORTANT!

It is important to adjust the saw head before starting to ensure satisfactory sawing and the correct functioning of the sawmill. Follow the setup sequence carefully! Certain adjustments affect other machine settings.



Arkiwägen 6, SE-871 53 Härnösand, Sweden
+46 611-182 85 | info@logosol.com | www.logosol.com