











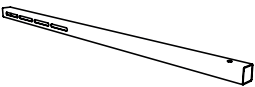



## MONTAGEANLEITUNG

Art.nr. 0458-395-0242

### INHALT





	_____	1 x	_____	03-02787
	_____	1 x	_____	03-02786
	_____	1 x	_____	03-02783
	_____	1 x	_____	03-02785
		— 1 x	_____	Inbusschraube M5x10
		— 1 x	_____	Inbusschraube M5x16
		— 8 x	_____	Inbusschraube M8x16
		— 1 x	_____	Endkappe
		— 8 x	_____	Flanschnutter M8
		— 1 x	_____	Magnet

Schraubentüte  
Schienenspitzenführung

# SCHIENENSPITZENFÜHRUNG SÄGEAGGREGAT

## MONTAGE: SCHIENENSPITZENFÜHRUNG

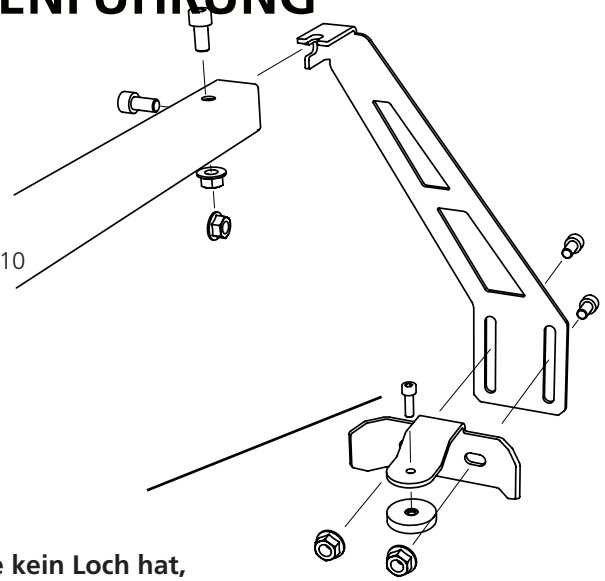

1

-  — 1 x — Inbusschraube M5x16 oder M5x10
-  — 4 x — Inbusschraube M8x16
-  — 4 x — Flanschmutter M8
-  — 1 x — Magnet



Falls Deine Schiene kein Loch hat,  
verwendest Du die kürzere Schraube die  
nicht durch den Magnet herausragt.

2

-  — 2 x — Inbusschraube M8x16
-  — 2 x — Flanschmutter M8

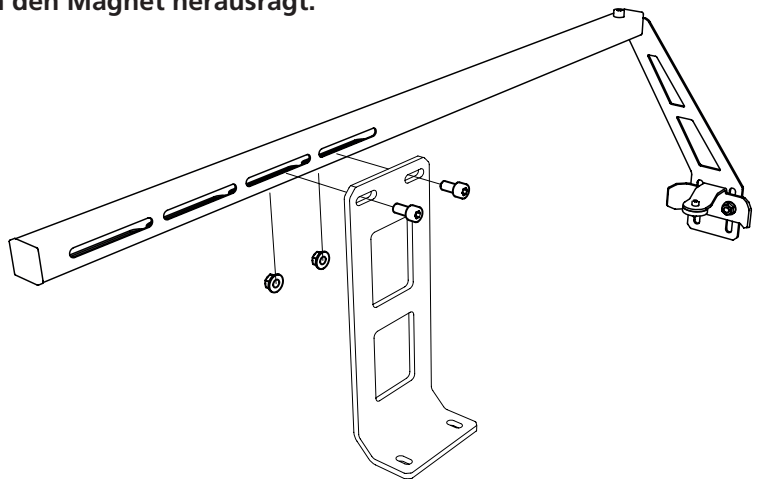

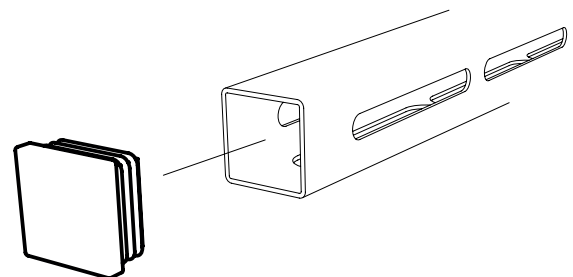

3

Montiere die Abdeckkappe am oberen Rohr.



# MONTAGE: SCHIENENSPIITZENFÜHRUNG

Montage der Schienenspitzenführung auf den Schlitten für die Motorsäge.

-  — 2 x — Inbusschraube M8x16
-  — 2 x — Flanschmutter M8

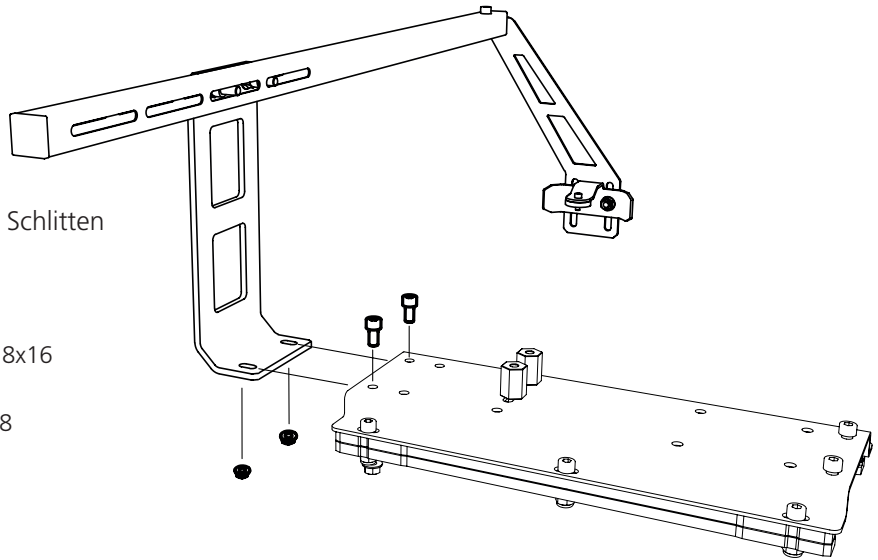

Montage der Schienenspitzenführung auf den Schlitten für die Elektrosäge.

-  — 2 x — Inbusschraube M8x16
-  — 2 x — Flanschmutter M8

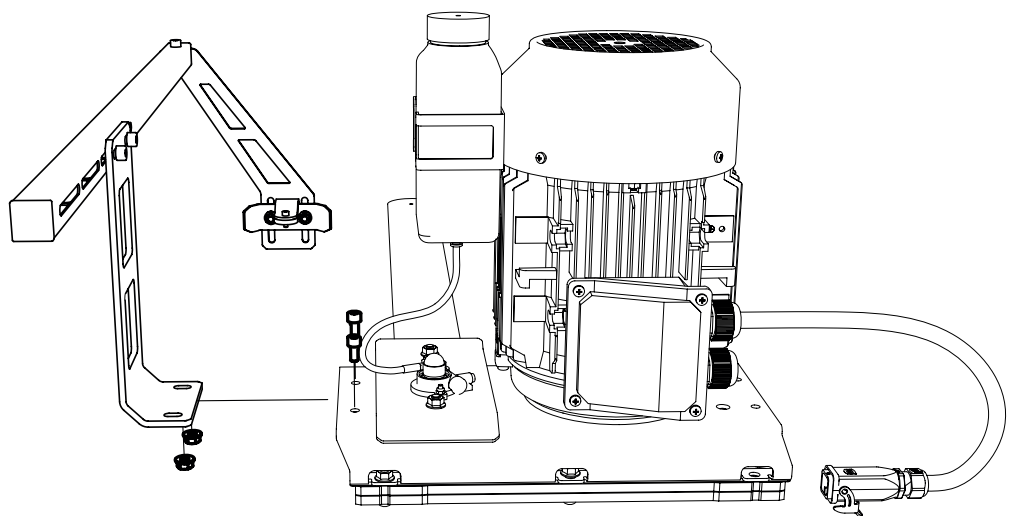

## EINSTELLUNG

Auf der Schienenspitzenführung besteht die Möglichkeit den Schienenspitzenhalter horizontal und vertikal zu verstellen.

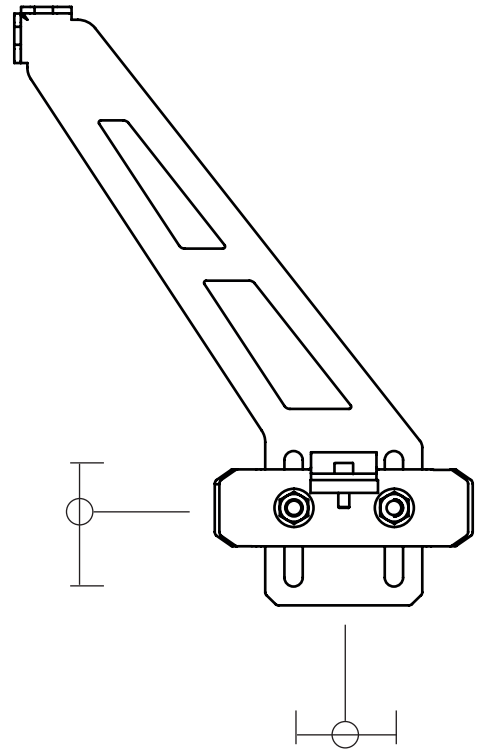

In dem oberen Rohr befinden sich Langlöcher. Stelle die Position des Rohres so ein, dass die Position der Schraube, die durch den Magnet geht, mit dem Loch in der Schwertspitze übereinstimmt

**Falls Deine Schiene kein Loch hat, verwendest Du eine kürzere Schraube die nicht durch den Magnet herausragt.**

