

MONTERINGSANVISNING

Art.nr. 0458-395-0410

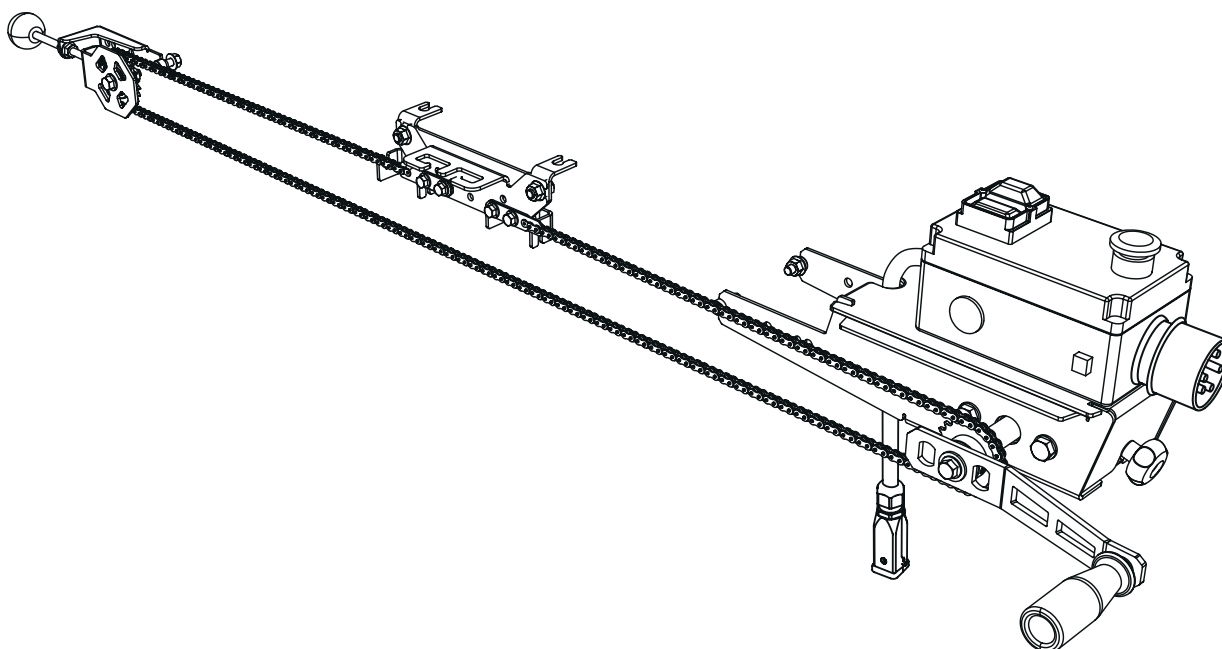









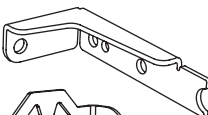
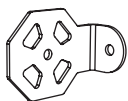

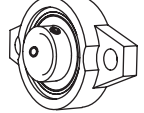
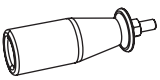

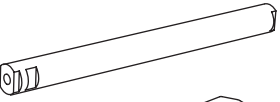
REV:1

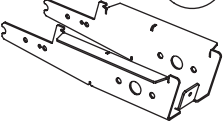

MANUELL FJÄRRDRIVNING FÖR ELSÅG

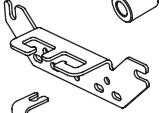
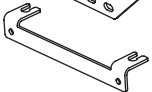
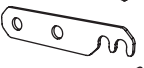

01-00696 INGÅENDE DELAR

| | | | | |
|---|-------|-----|-------|---------------|
|  | _____ | 1 x | _____ | 03-02832 |
|  | _____ | 1 x | _____ | 03-03156 |
|  | _____ | 1 x | _____ | 04-00561 |
|  | _____ | 1 x | _____ | 03-03158 |
|  | _____ | 2 x | _____ | 04-00409 |
|  | _____ | 1 x | _____ | DS-00169 |
|  | _____ | 1 x | _____ | 03-03239 |
|  | _____ | 1 x | _____ | 03-02819 |
|  | _____ | 1 x | _____ | 03-02813 |
|  | _____ | 1 x | _____ | 04-00407 |
|  | _____ | 1 x | _____ | DK-00110 |
|  | _____ | 1 x | _____ | 03-02811 |
|  | _____ | 1 x | _____ | 03-03159 |
|  | _____ | 1 x | _____ | 03-02797 |
|  | _____ | 1 x | _____ | 03-02796 |
|  | _____ | 4 x | _____ | 03-03157 |
|  | _____ | 1 x | _____ | 01-00697, 4 m |
|  | _____ | 1 x | _____ | 01-00696-skp |
|  | _____ | 1 x | _____ | 01-00777-skp |

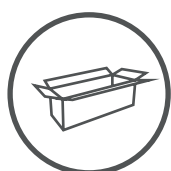
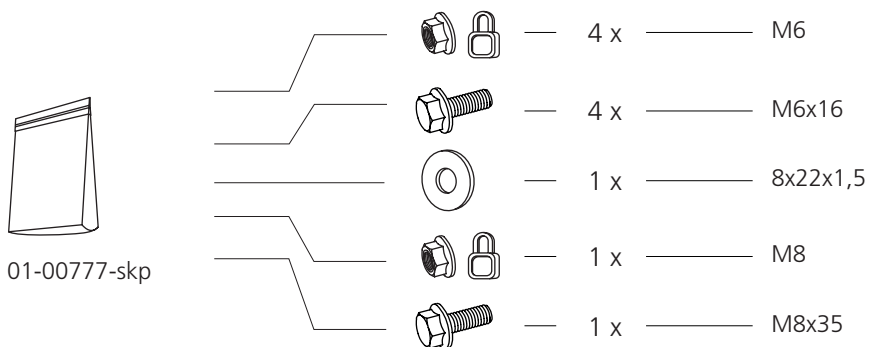
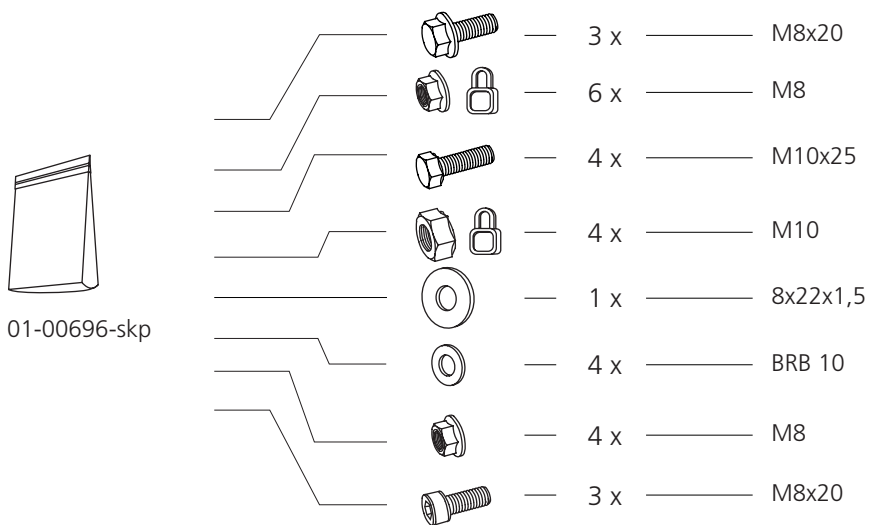

01-00804

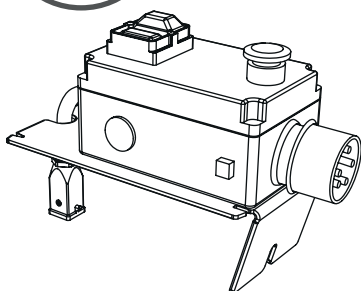

— 1 x — 01-00804

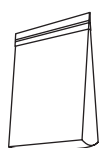

— 1 x — 01-00720, 1 m
Används för varje 1 m förlängning

01-00720



01-00696

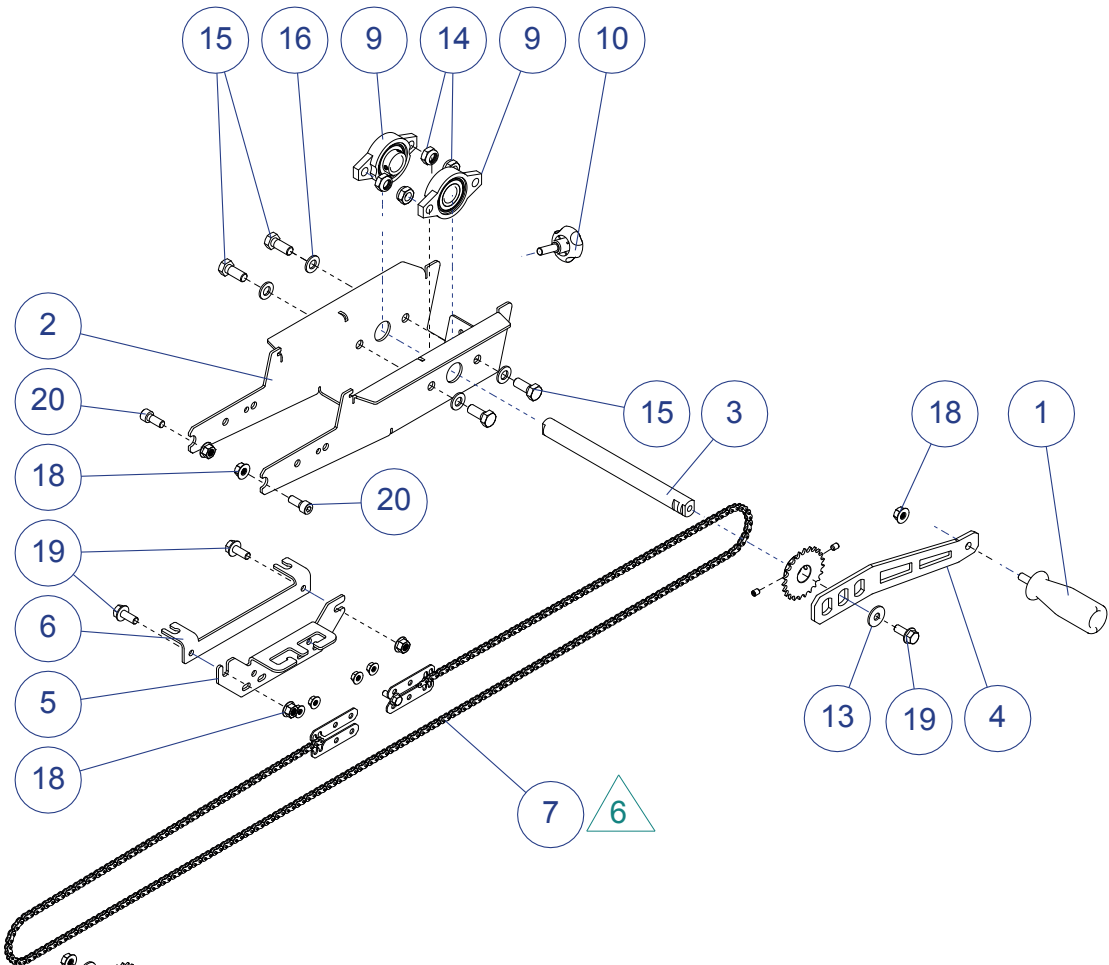

Exploded view

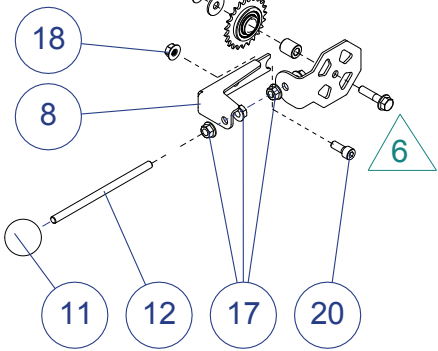

| | | | | |
|-----------------|----------------|-------------|-----------------------------|--------------|
| 20 | MC6S M8x20 | 3 | Allen screw | |
| 19 | M6SF M8x20 | 3 | Flange screw M6SF DIN 6921 | |
| 18 | LM6MF M8 Fzb | 6 | Nylon lock flange nut Fzb | |
| 17 | M6MF M8 | 4 | Flange nut M8 Fzb | |
| 16 | BRB 10 | 4 | Washer 10,5x22 t=2 Fzb | |
| 15 | M6S M10x25 | 4 | Hex screw M6S Fzb | |
| 14 | LM6M M10 | 4 | Hex Nylon Lock Nut Fzb | |
| 13 | ISO 4759/3 | 1 | Washer NB 8x22x1,5 | |
| 12 | 03-03239 | 1 | Threaded rod M8x150 8.8 fzb | 1 |
| 11 | DK-00110 | 1 | Endcap WN319 G32-M8 | 1 |
| 10 | 04-00407 | 1 | Knob M8x25 | 1 |
| 9 | 04-00409 | 2 | Flanged bearing Ø20 KFL004 | 1 |
| 8 | 03-02832 | 1 | Turn wheel bracket | 1 |
| 7 | 01-00777 | 1 | Manual feed chain kit | 4 |
| 6 | 03-02796 | 1 | Bracket | 2 |
| 5 | 03-02797 | 1 | Cable & Wire mount | 1 |
| 4 | 03-02813 | 1 | Crank handle | 1 |
| 3 | 03-02819 | 1 | Crankshaft | 1 |
| 2 | 03-02811 | 1 | Chassis | 1 |
| 1 | DS-00169 | 1 | Handle w.out end cap | 2 |
| Item no. | Art.no. | Qty. | Description | Issue |



01-00777

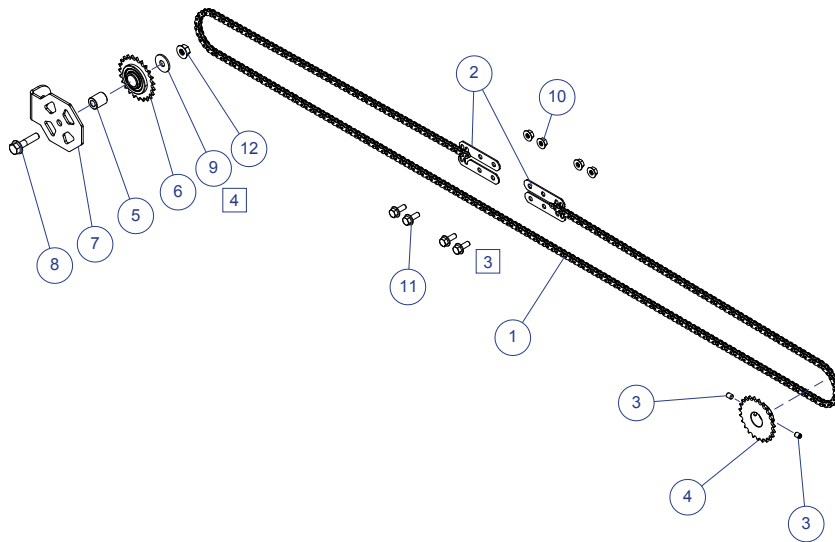

| | | | | |
|-----------------|----------------|-------------|-------------------------------|--------------|
| 12 | LM6MF M8 Fzb | 1 | Nylon lock flange nut Fzb | |
| 11 | M6SF M6x16 | 4 | Flänsskruv M6SF DIN 6921 | |
| 10 | LM6MF M6 | 4 | Nylon lock flange nut Fzb | |
| 9 | ISO 4759/3 | 1 | Washer NB 8x22x1,5 | |
| 8 | M6SF M8x35 | 1 | Flange screw M6SF DIN 6921 | |
| 7 | 03-03156 | 1 | Turn wheel plate | 1 |
| 6 | 04-00561 | 1 | 05B-1 Z=23 Tension sprocket | 1 |
| 5 | 03-03159 | 1 | Spacer D=15,8x8,1 L=18,5 | 1 |
| 4 | 03-03158 | 1 | Sprocket 05B-1 z=23 d=20 L=14 | 1 |
| 3 | P6SS M6x8 | 2 | Pin screw | |
| 2 | 03-03157 | 4 | Chainholder | 1 |
| 1 | 01-00697 | 1 | Feed Chain (Manual) | 1 |
| Item no. | Art.no. | Qty. | Description | Issue |

SKRUV/MUTTER

Definition av fästelementen på kommande sidor.

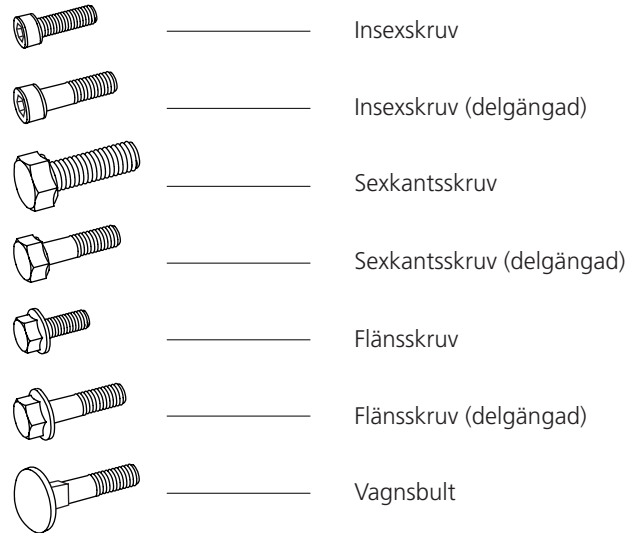

TILLÄGGSSYMBOLER

Följande symboler används som ett tillägg till bilderna ovanför för att beskriva detaljens utformning.



Låg



Tensilock



Lås



Försänkt

MÅTT/LÄNGD

Måtten på fästelementen skrivs ut som ett diametermått (**M**) ISO 68-1. Därefter följer för skruvar ett längdmått, måttet på skruven är den del av skruven som försvinner i materialet den monteras i.

(Diameter)

M8

(Längd)

x







20

MONTERING





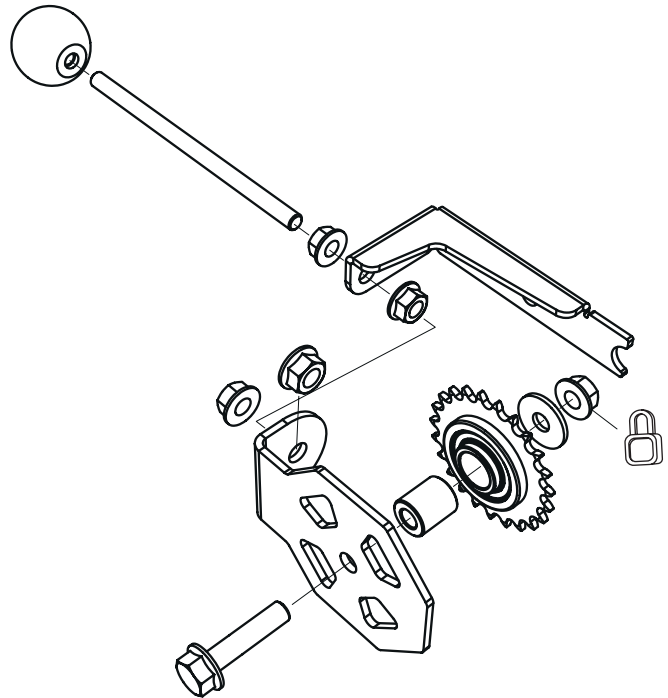

01-00696

1

-  — 1 x — 8x22x1,5
-  — 1 x — M8x35
-  — 4 x — M8
-  — 1 x — M8
-  — 1 x — 04-00561
-  — 1 x — 03-03159

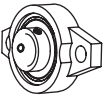



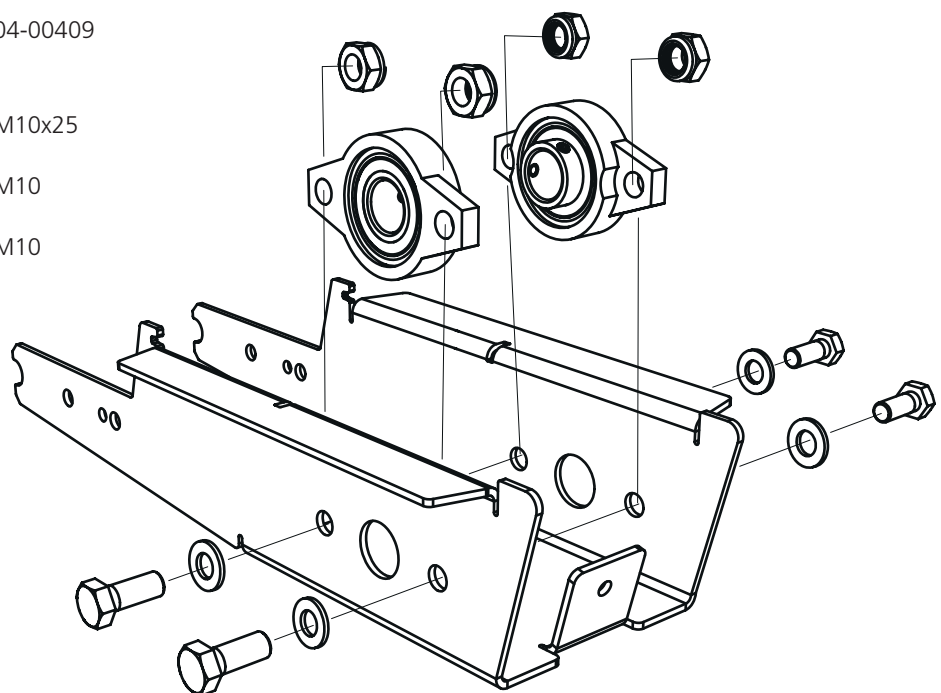

2

-  — 2 x — 04-00409
-  — 4 x — M10x25
-  — 4 x — M10
-  — 4 x — M10



3

Montering av vevhandtag

-  — 1 x — 8x22x1,5
-  — 1 x — M8x20
-  — 1 x — M8
-  — 1 x — 03-03158

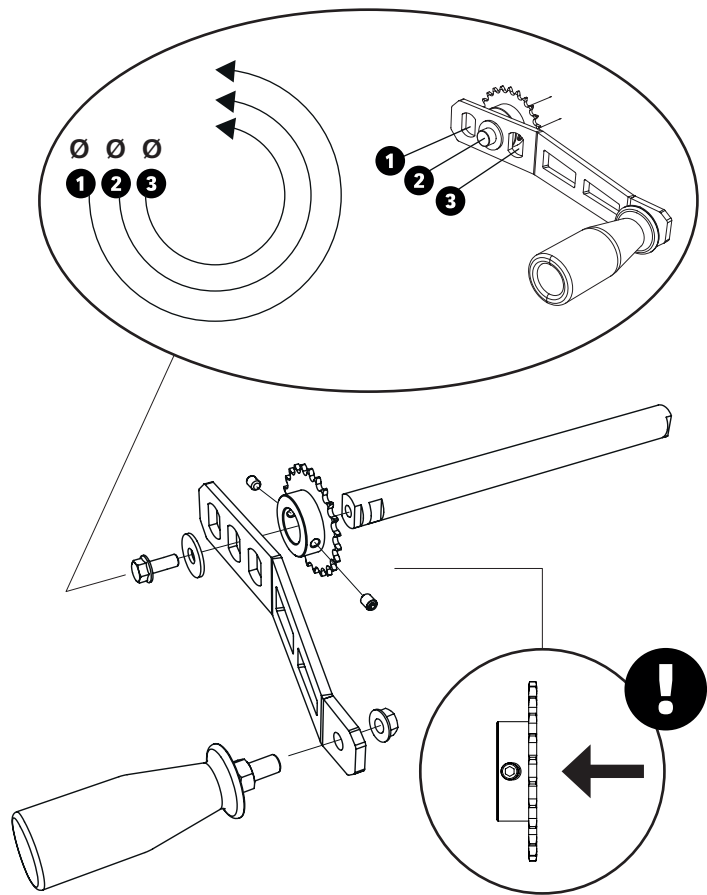

Vevhandtaget går att montera på både höger och vänster sida.

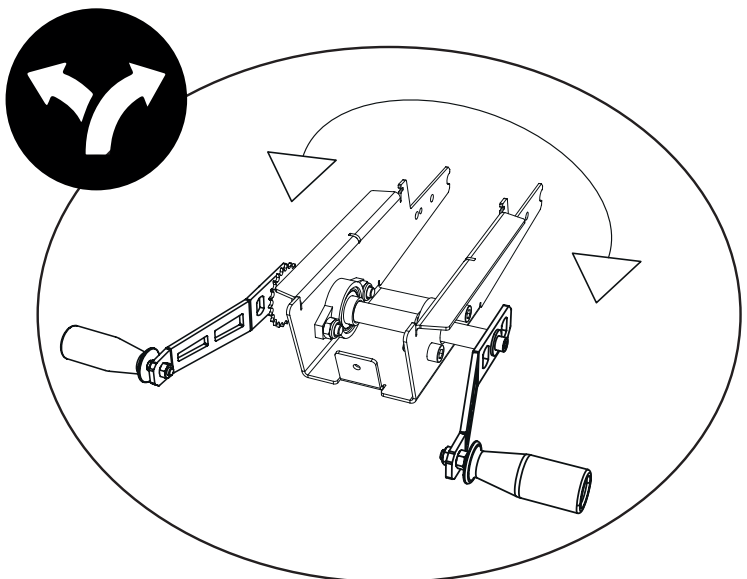

4

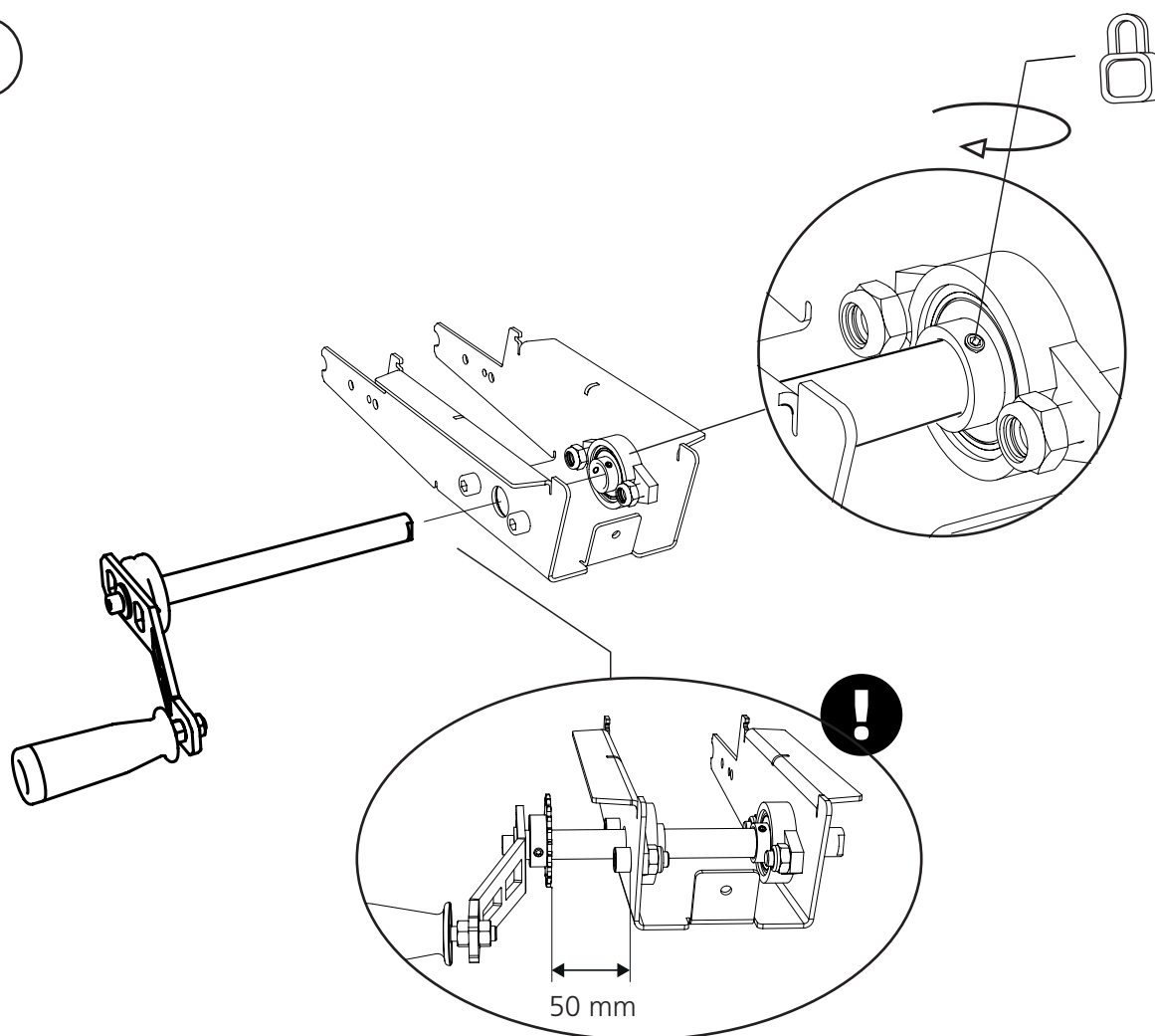

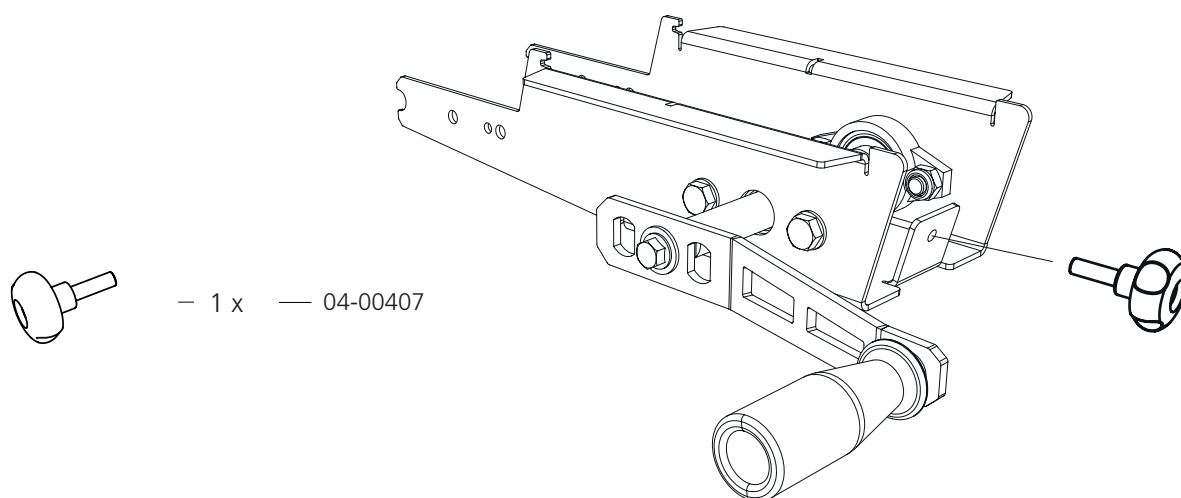

5



6

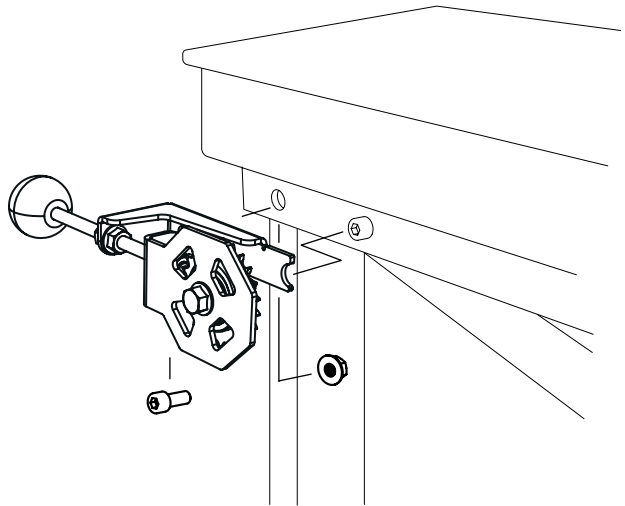

Montaget utförs delvis med balkens befintliga skruvförband.

-  — 1 x — M8x20
-  — 1 x — M8



7

Montaget utförs delvis med balkens befintliga skruvförband.

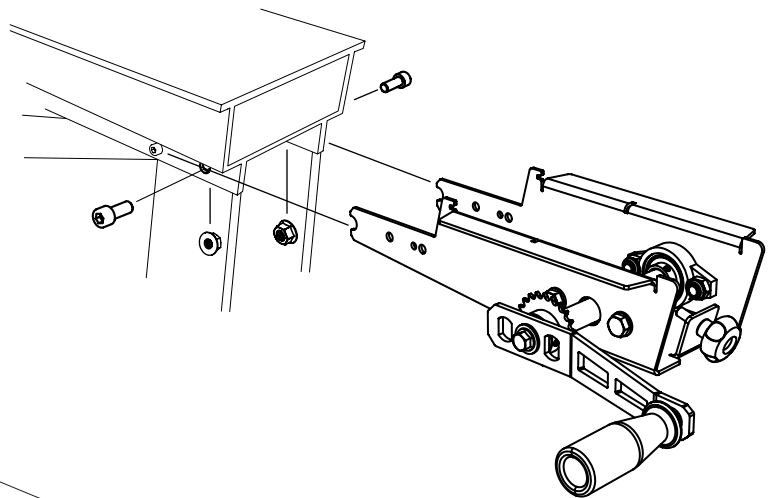

-  — 2 x — M8x20
-  — 2 x — M8

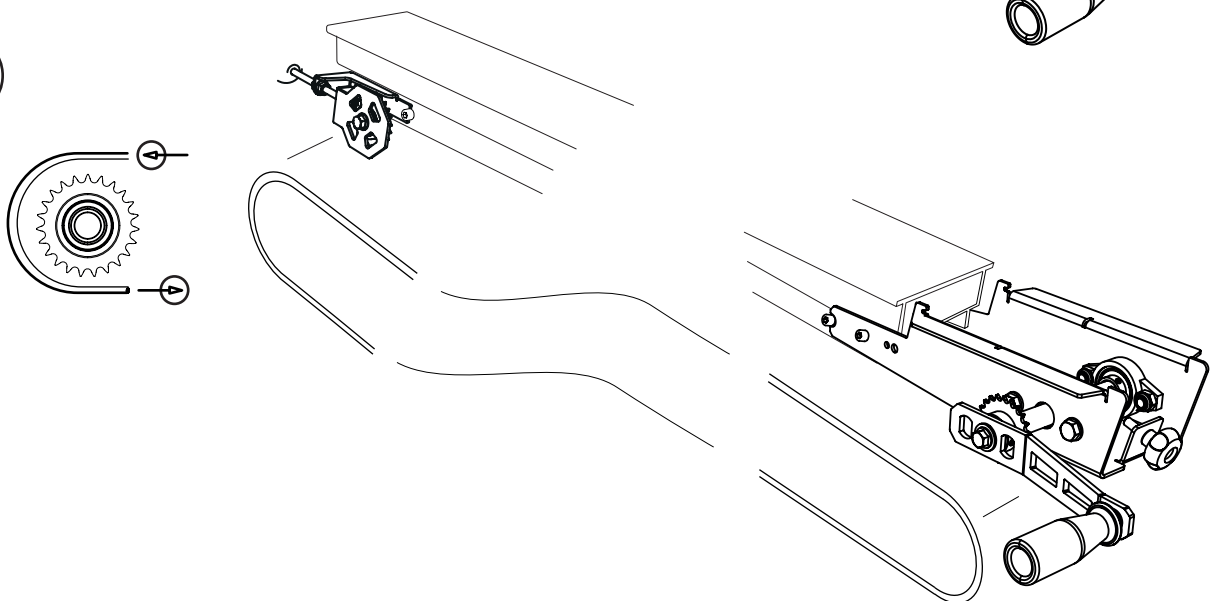

8



9



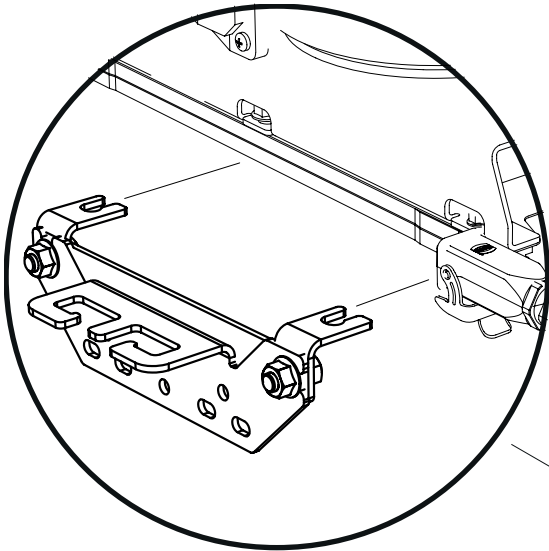
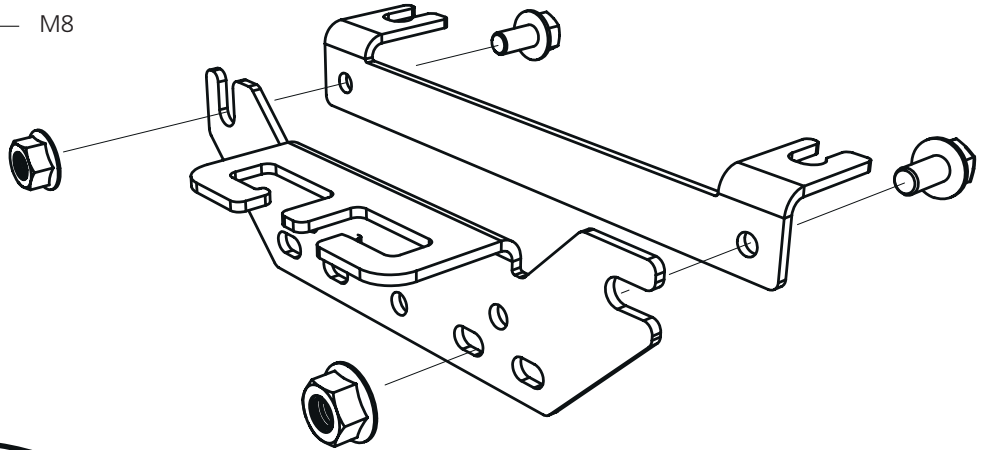

-  — 2 x — M8x20
-  — 2 x — M8

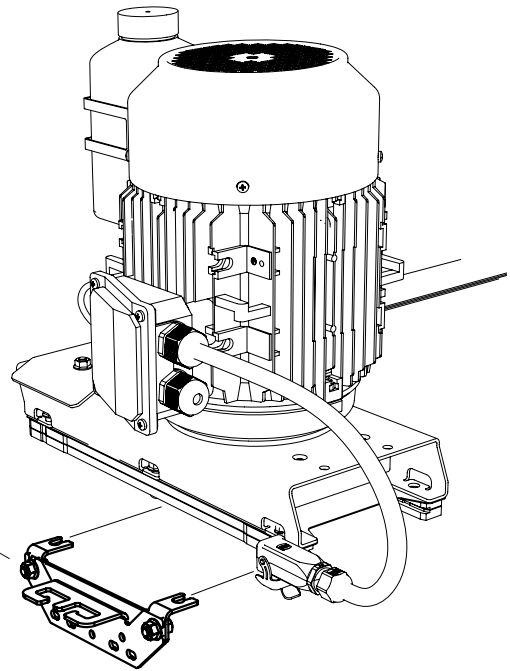

Montaget utförs med slädens befintliga skruvförband.



10

-  — 4 x ————— M6x16
-  — 4 x ————— M6
-  1 x ————— 01-00697, 4 m
-  1 x ————— 01-00720, 1 m
Används för varje 1 m förlängning

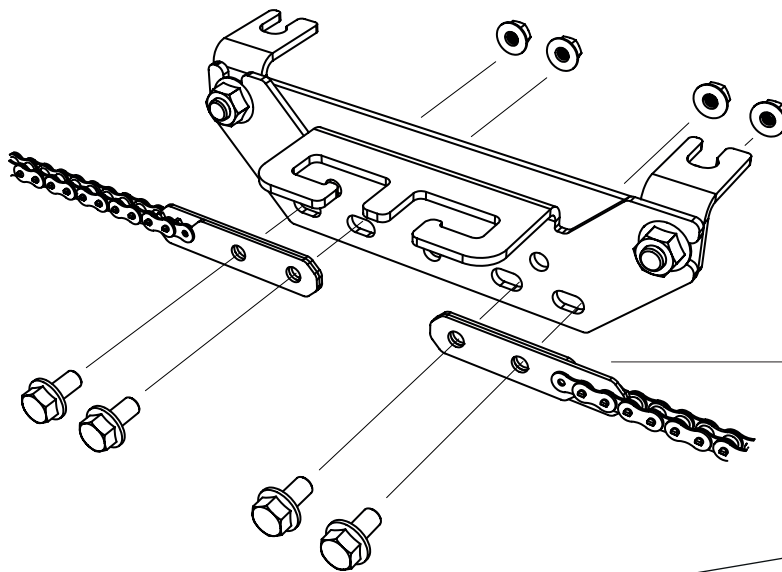
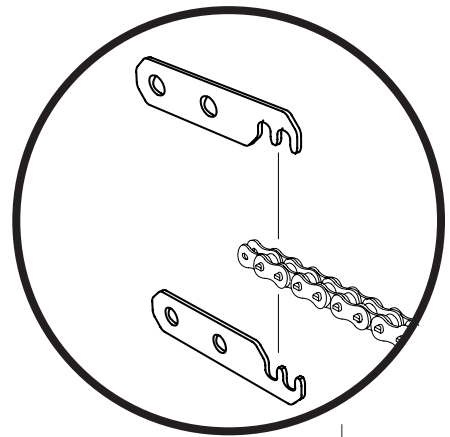

11

Spänn upp drivkedjan så att det är 6-7 cm mellan kedjorna.

För att kunna justera spänningen behöver man släppa på spännmekanismens flänsmutter.

Efter slutförd justering, var noga med att återdra flänsmuttern.

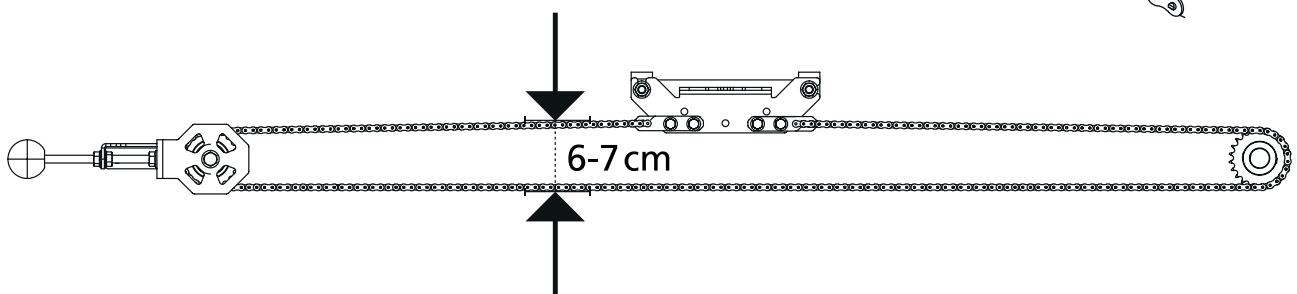
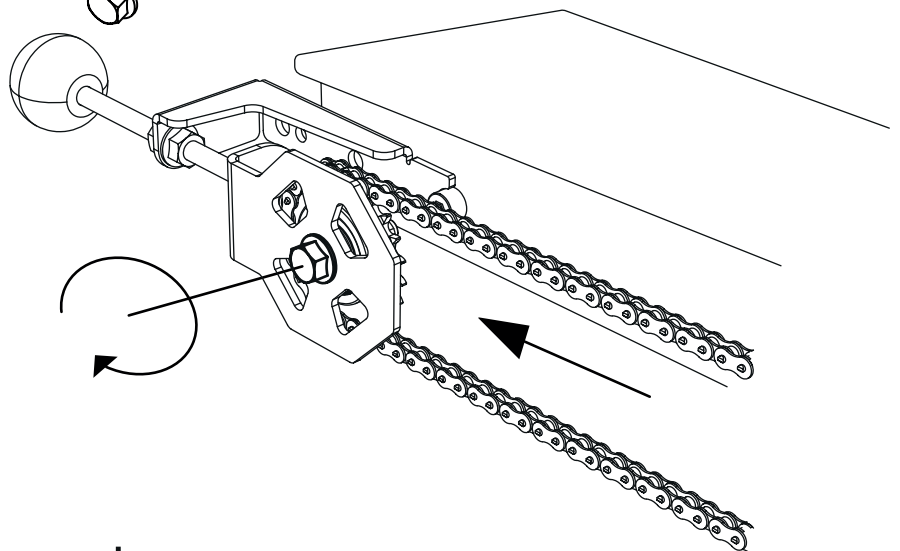



01-00804

12

Toppytan på fjärrdrivningen kan monteras bort för att möjliggöra förvaring av eldonet på annan plats än vid sågverket när den inte används.

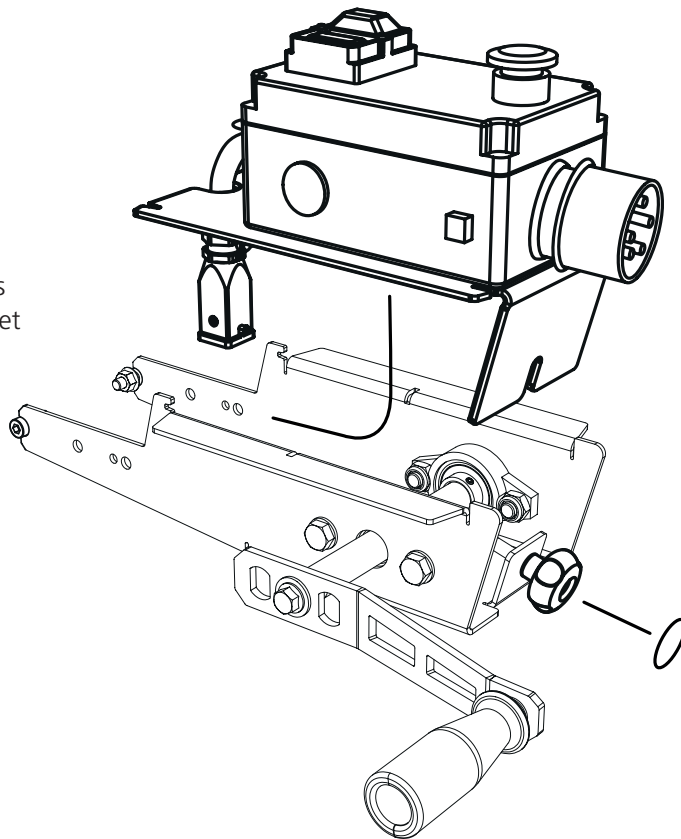

13

Fäst matningskabeln till sågaggregatet i kabelfästet på vajerfästplåten.

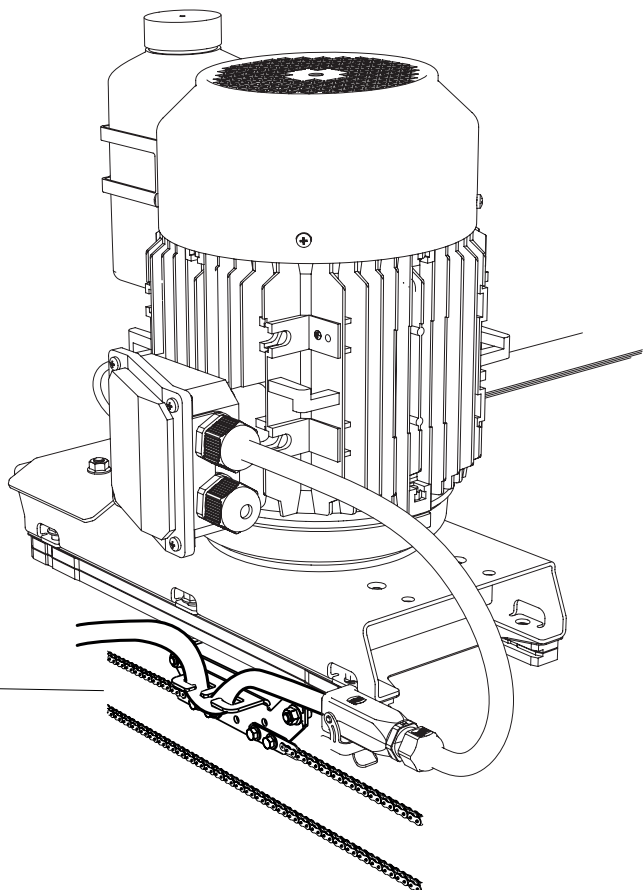
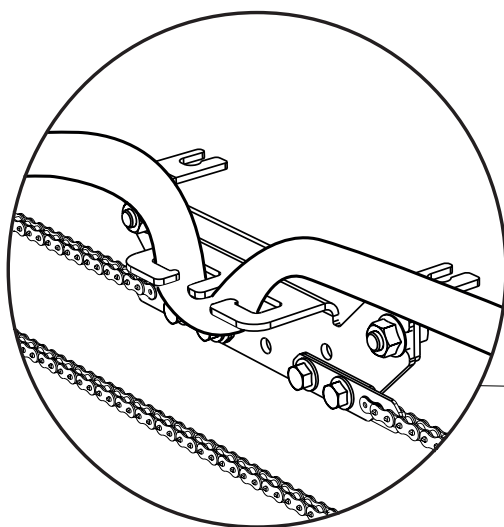



Försäkran om överensstämmelse

Enligt direktiv 2006/42/EG, Bilaga 2A

Logosol AB,
Fiskaregatan 2,
S-871 33 Härnösand
Tfn +46 611 18285,

försäkrar härmed att **Logosol Manuell
fjärrdrivning för elsåg**

är tillverkad i överensstämmelse med: Maskin-
direktivet 2006/42/EG, EMC-direktivet 2014/30/EU

samt är tillverkad i överensstämmelse medföljande
harmoniserade standarder:
EN ISO 12100:2010, EN 60204-1:2018

Härnösand 2022-10-27

Fredrik Forsberg, VD

 **LOGOSOL**

Fiskaregatan 2, 871 33 Härnösand
0611-182 85 | info@logosol.se | www.logosol.se