

**LOGOSOL**

# **INSTRUCCIONES DE MONTAJE**

N.º de ref. 0458-395-0425

REV:1

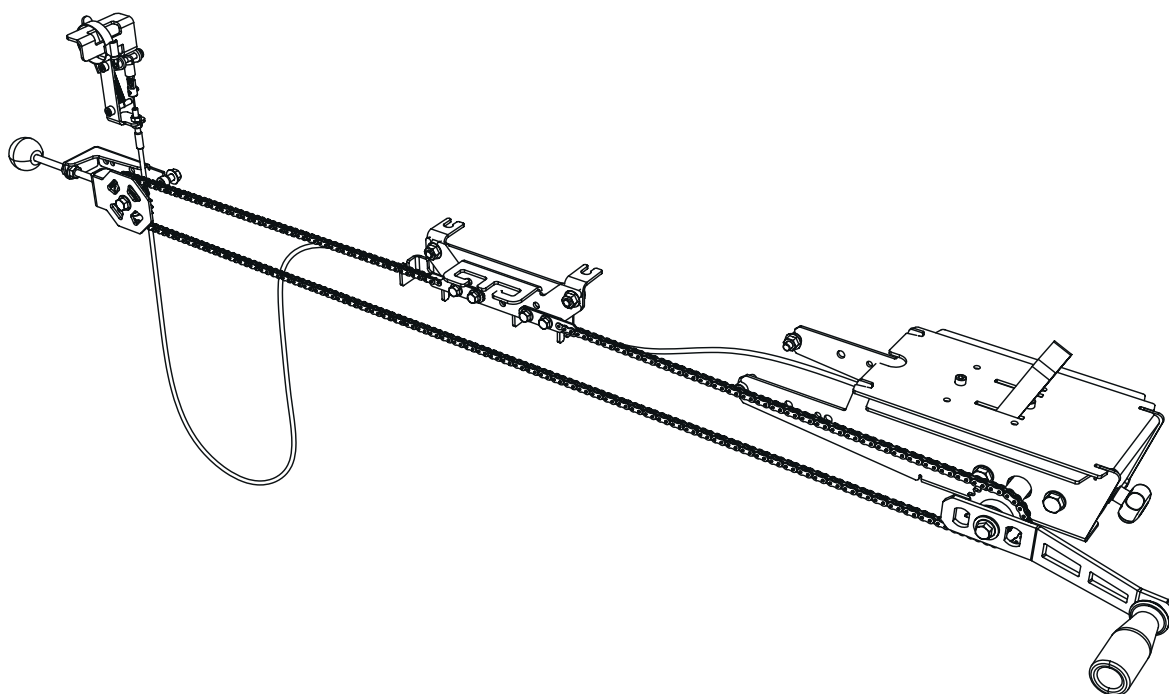









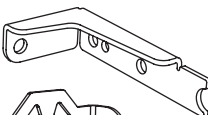
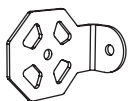

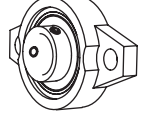
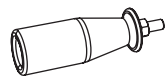

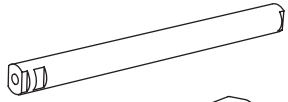

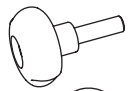
## **ALIMENTACIÓN MANUAL DE DISTANCIA PARA MOTOSIERRA**

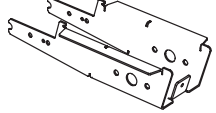
**ES**

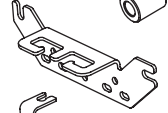
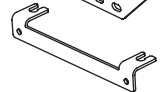

## 01-00696 COMPONENTES

	_____	1 x	_____	03-02832
	_____	1 x	_____	03-03156
	_____	1 x	_____	04-00561
	_____	1 x	_____	03-03158
	_____	2 x	_____	04-00409
	_____	1 x	_____	DS-00169
	_____	1 x	_____	03-03239
	_____	1 x	_____	03-02819
	_____	1 x	_____	03-02813
	_____	1 x	_____	04-00407
	_____	1 x	_____	DK-00110
	_____	1 x	_____	03-02811
	_____	1 x	_____	03-03159
	_____	1 x	_____	03-02797
	_____	1 x	_____	03-02796
	_____	4 x	_____	03-03157
	_____	1 x	_____	01-00697, 4 m
	_____	1 x	_____	01-00696-skp
	_____	1 x	_____	01-00777-skp

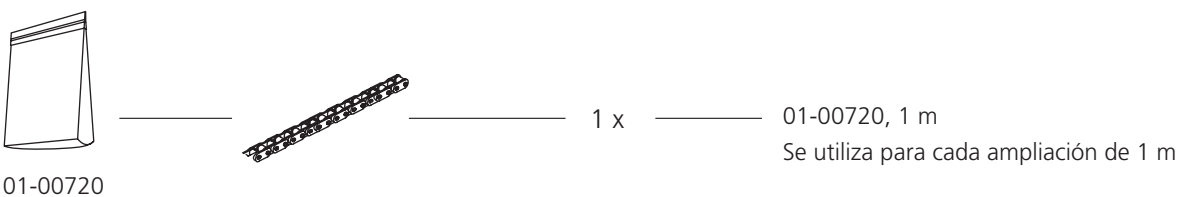
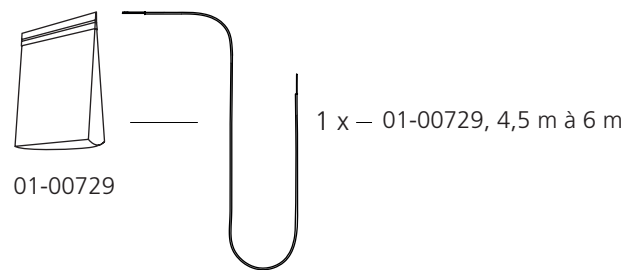
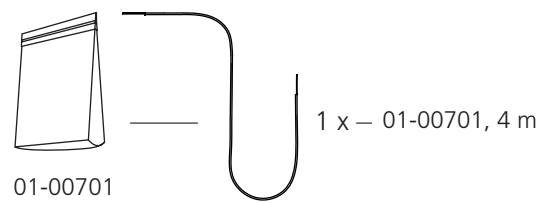
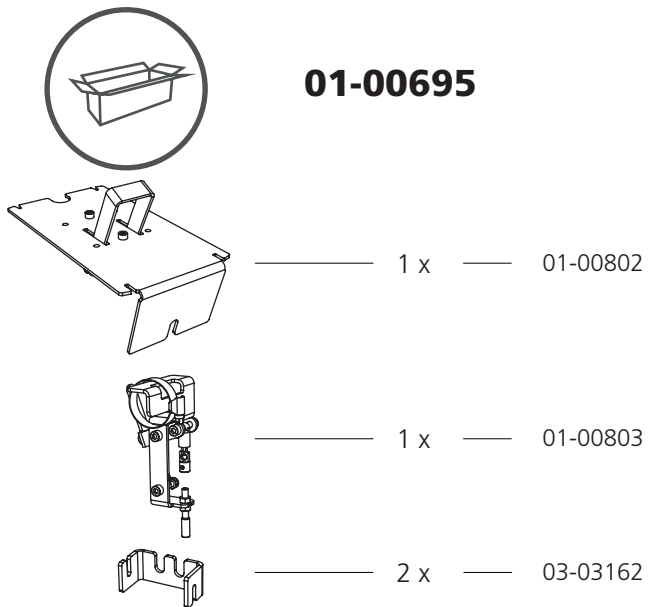
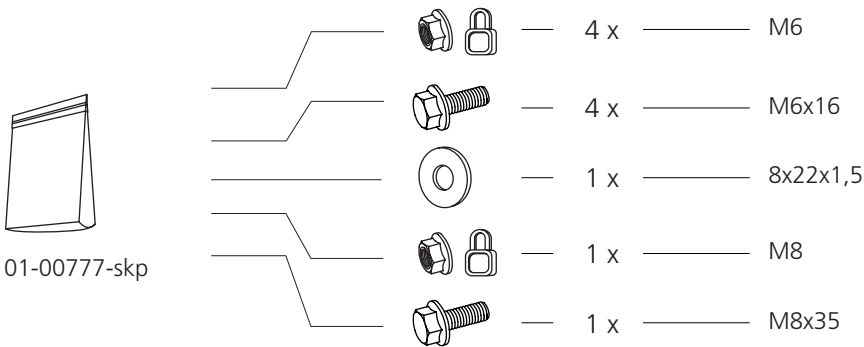
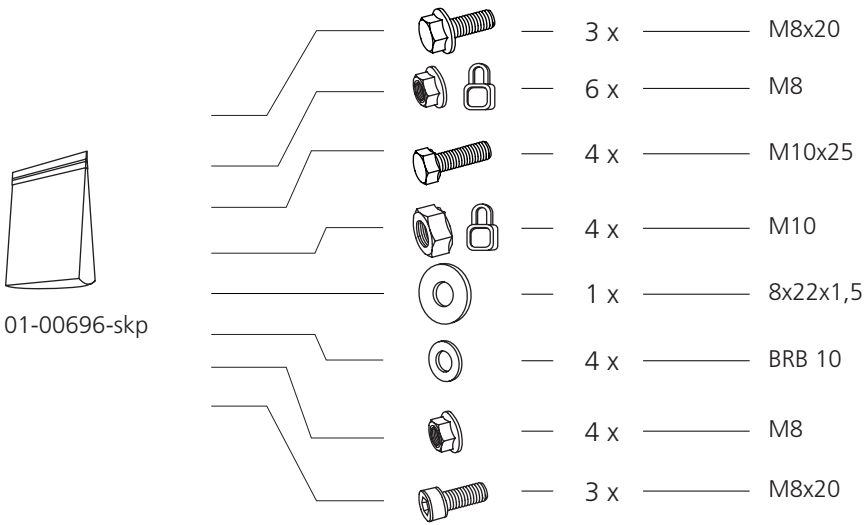



01-00696

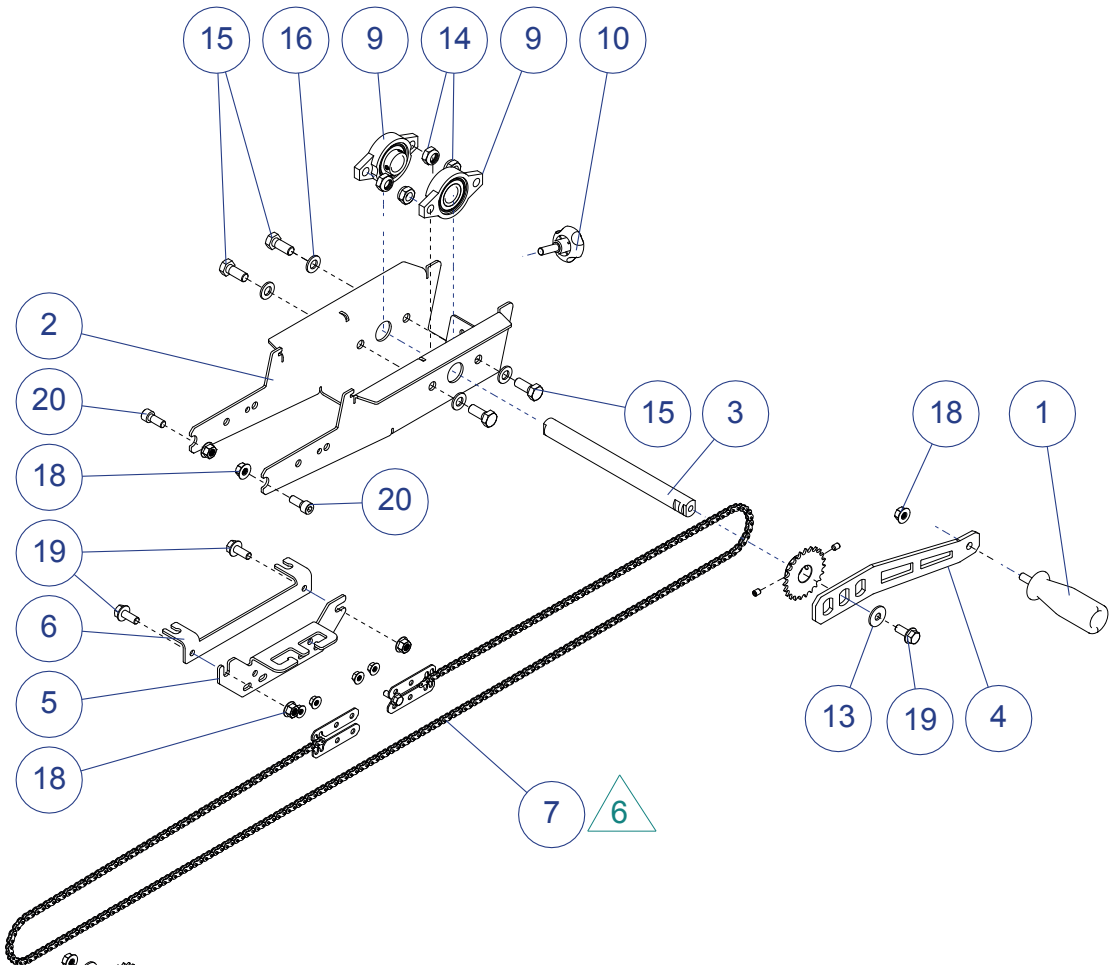

Exploded view

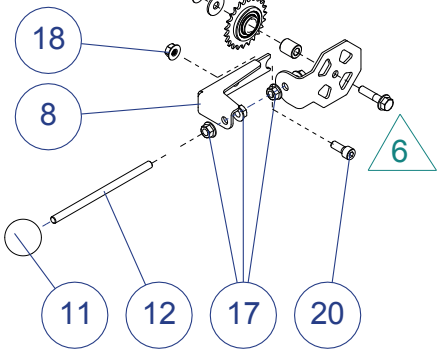

20	MC6S M8x20	3	Allen screw	
19	M6SF M8x20	3	Flange screw M6SF DIN 6921	
18	LM6MF M8 Fzb	6	Nylon lock flange nut Fzb	
17	M6MF M8	4	Flange nut M8 Fzb	
16	BRB 10	4	Washer 10,5x22 t=2 Fzb	
15	M6S M10x25	4	Hex screw M6S Fzb	
14	LM6M M10	4	Hex Nylon Lock Nut Fzb	
13	ISO 4759/3	1	Washer NB 8x22x1,5	
12	03-03239	1	Threaded rod M8x150 8.8 fzb	1
11	DK-00110	1	Endcap WN319 G32-M8	1
10	04-00407	1	Knob M8x25	1
9	04-00409	2	Flanged bearing Ø20 KFL004	1
8	03-02832	1	Turn wheel bracket	1
7	01-00777	1	Manual feed chain kit	4
6	03-02796	1	Bracket	2
5	03-02797	1	Cable & Wire mount	1
4	03-02813	1	Crank handle	1
3	03-02819	1	Crankshaft	1
2	03-02811	1	Chassis	1
1	DS-00169	1	Handle w.out end cap	2
<b>Item no.</b>	<b>Art.no.</b>	<b>Qty.</b>	<b>Description</b>	<b>Issue</b>



01-00777

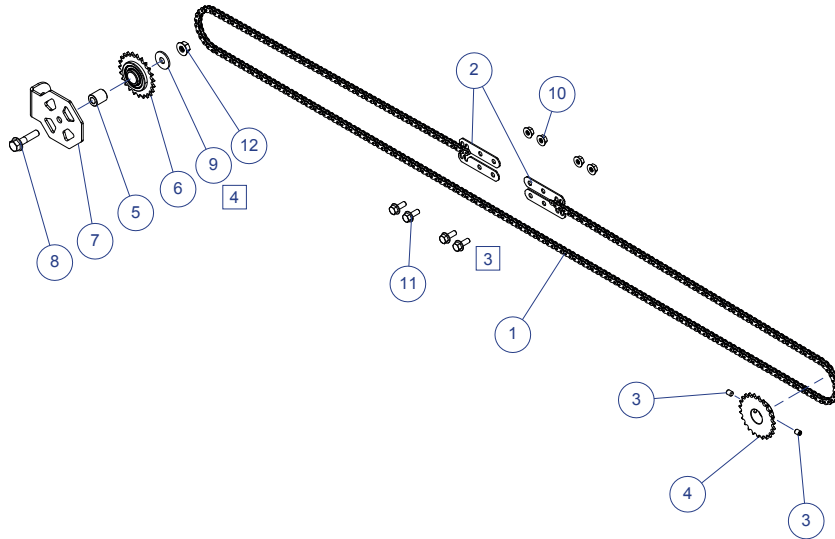

12	LM6MF M8 Fzb	1	Nylon lock flange nut Fzb	
11	M6SF M6x16	4	Flänsskruv M6SF DIN 6921	
10	LM6MF M6	4	Nylon lock flange nut Fzb	
9	ISO 4759/3	1	Washer NB 8x22x1,5	
8	M6SF M8x35	1	Flange screw M6SF DIN 6921	
7	03-03156	1	Turn wheel plate	1
6	04-00561	1	05B-1 Z=23 Tension sprocket	1
5	03-03159	1	Spacer D=15,8x8,1 L=18,5	1
4	03-03158	1	Sprocket 05B-1 z=23 d=20 L=14	1
3	P6SS M6x8	2	Pin screw	
2	03-03157	4	Chainholder	1
1	01-00697	1	Feed Chain (Manual)	1
<b>Item no.</b>	<b>Art.no.</b>	<b>Qty.</b>	<b>Description</b>	<b>Issue</b>

## TORNILLO/TUERCA

Definición de los elementos de fijación en las páginas siguientes.

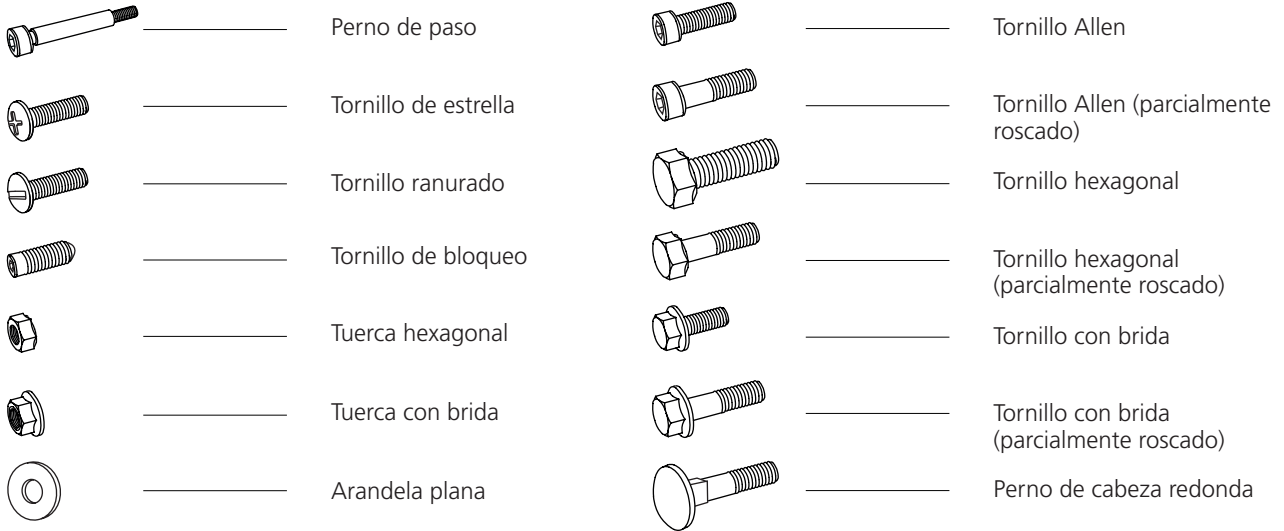

### SÍMBOLOS ADICIONALES

Los siguientes símbolos se utilizan como una adición a las imágenes anteriores para describir el diseño del detalle.



Bajo



Tensilock



Cierre



Empotrado

### DIMENSIONES/LONGITUD

Las dimensiones de los elementos de fijación se indican como una medida de diámetro (**M**) ISO 68-1. A continuación, para los tornillos se incluye una medida de longitud; las dimensiones del tornillo son la parte del tornillo que se introduce en el material en el que se monta.

**(Diámetro)**                      **(Longitud)**

M8

x







20

# MONTAJE





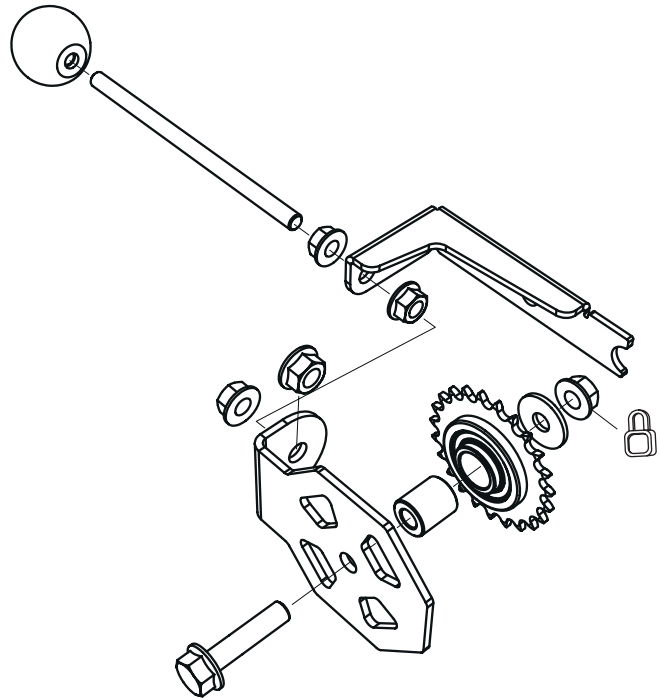

**01-00696**

**1**

-  — 1 x — 8x22x1,5
-  — 1 x — M8x35
-  — 4 x — M8
-  — 1 x — M8
-  — 1 x — 04-00561
-  — 1 x — 03-03159





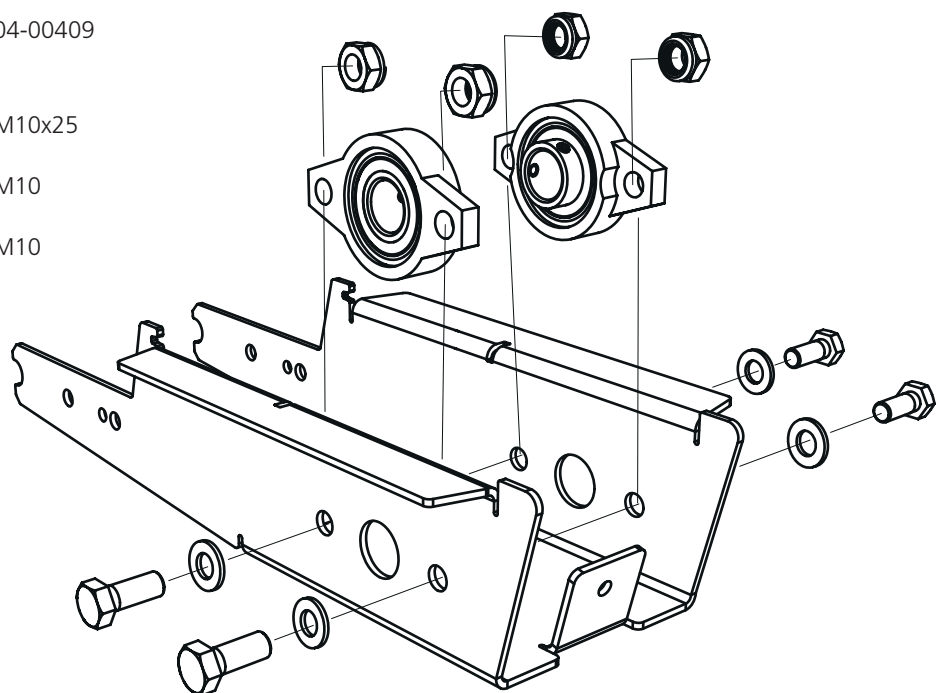

**2**

-  — 2 x — 04-00409
-  — 4 x — M10x25
-  — 4 x — M10
-  — 4 x — M10



**3**

## Montaje de las asas de manivela

-  — 1 x — 8x22x1,5
-  — 1 x — M8x20
-  — 1 x — M8
-  — 1 x — 03-03158

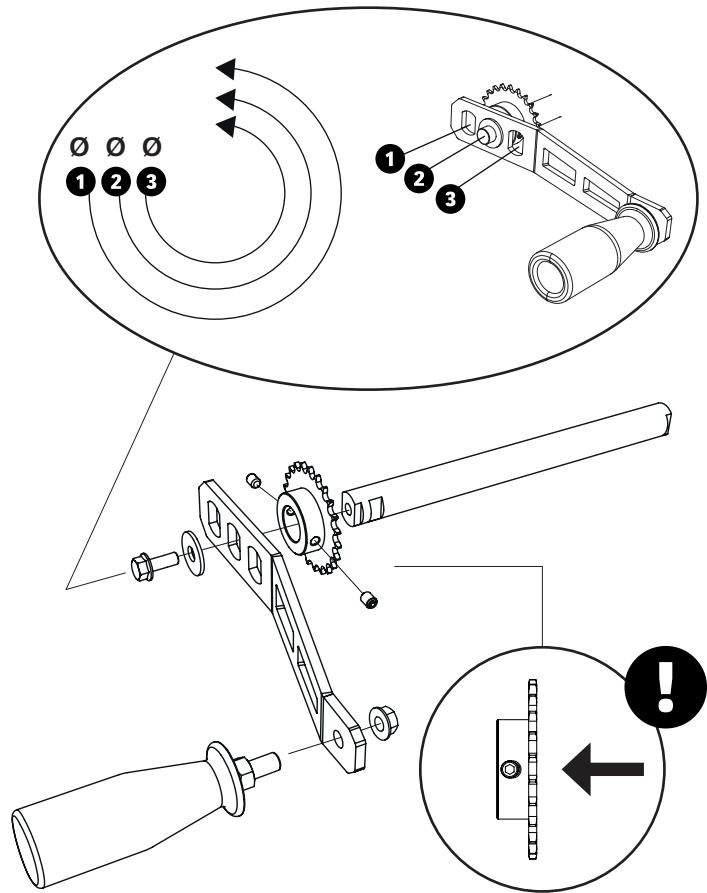

El asa de manivela se puede montar tanto en el lado derecho como en el izquierdo.

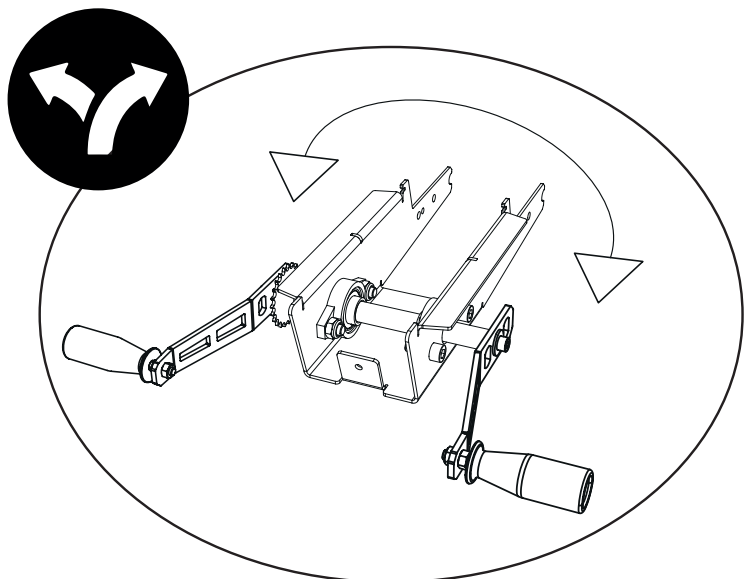



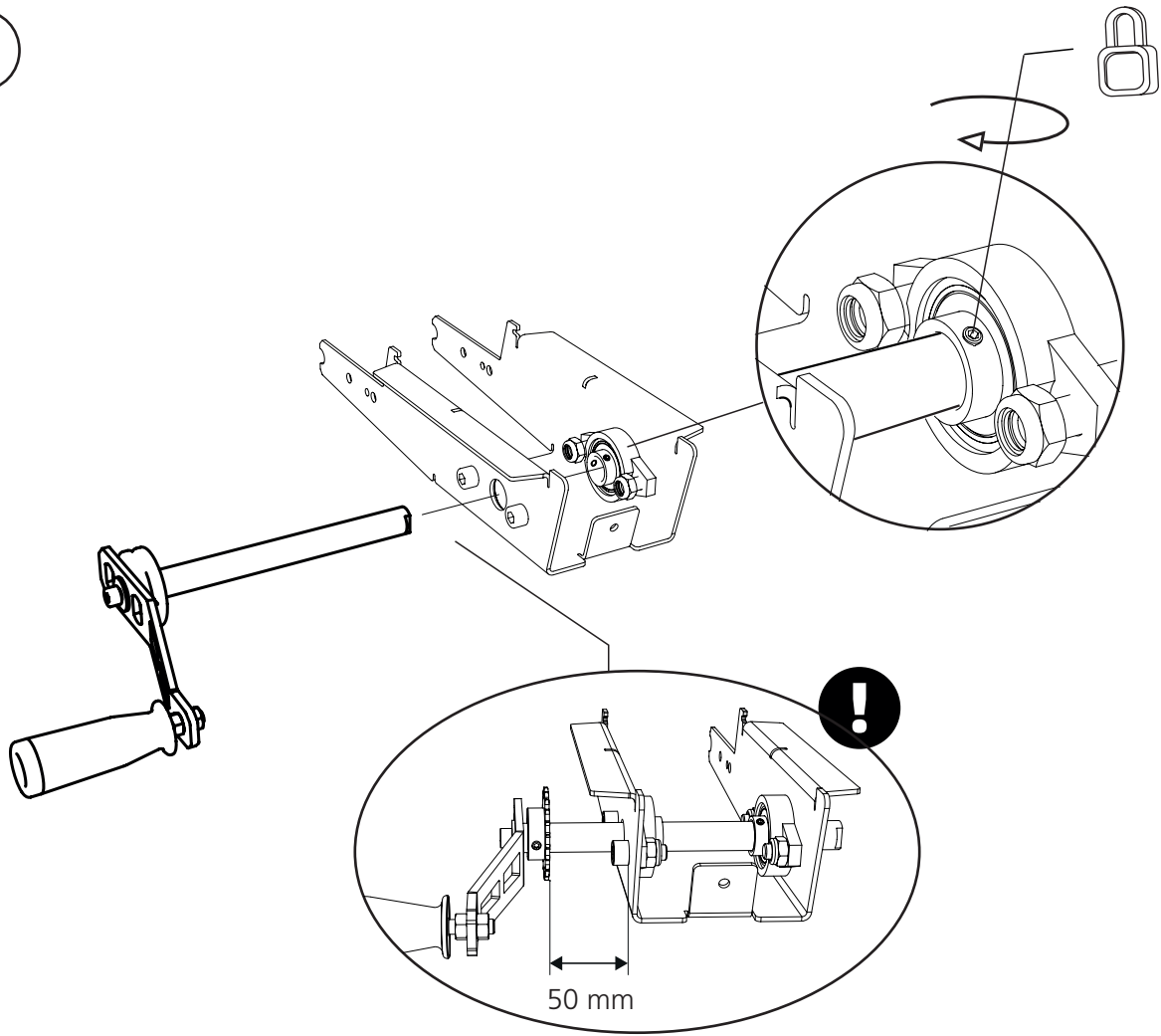

4

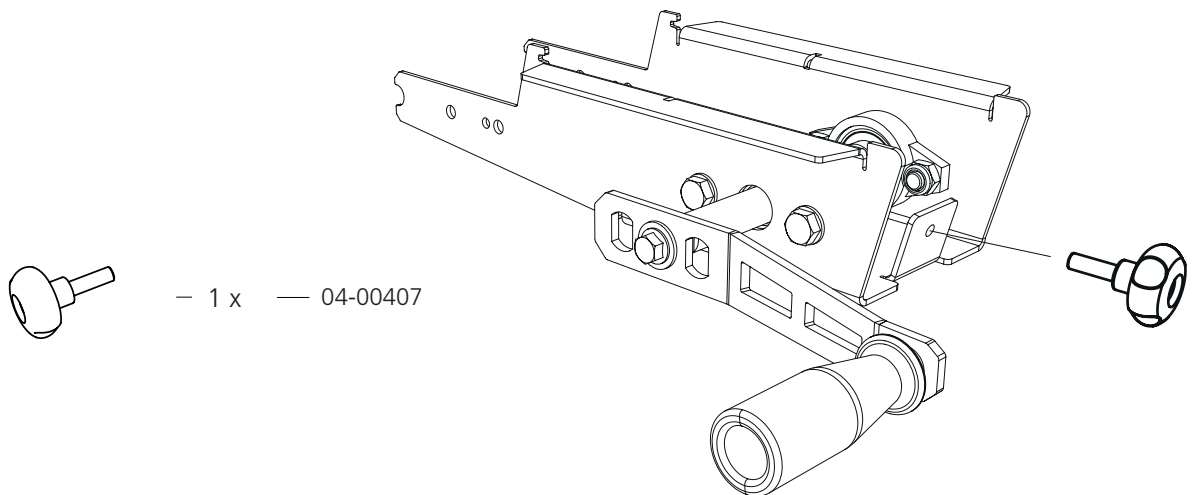

5



6

 — 2 x — M8x20

 — 2 x — M8

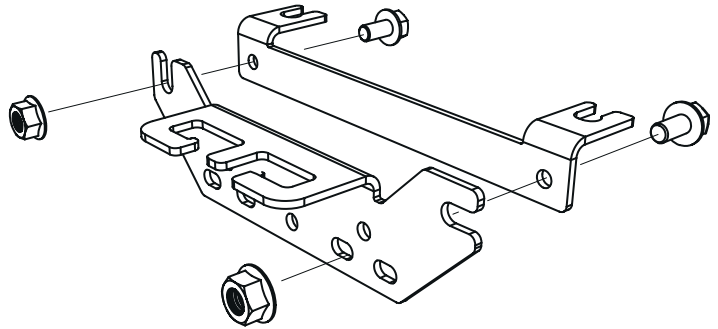

7

El montaje se lleva a cabo con las uniones atornilladas existentes en la plataforma.



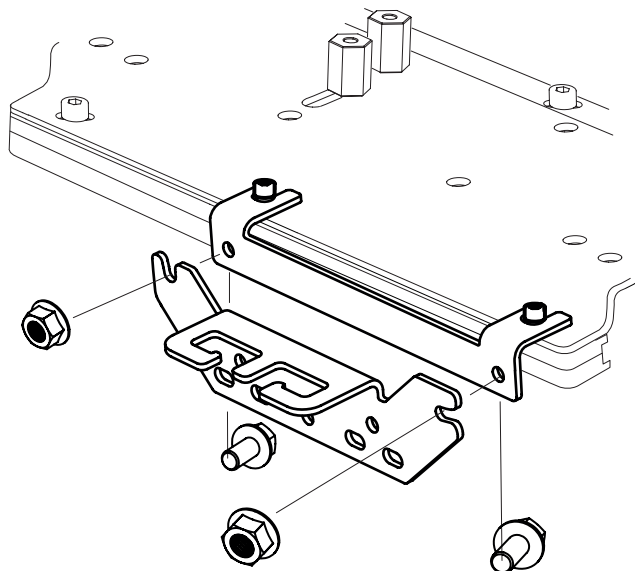
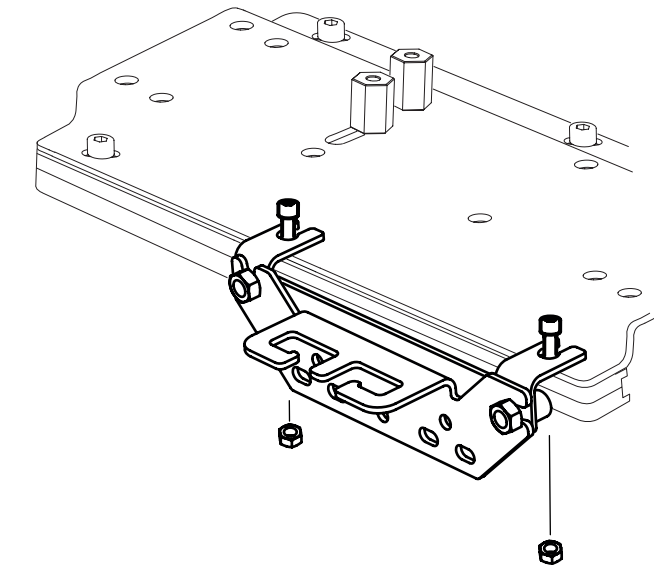

 — 2 x — M8x35

 — 2 x — M8



Para facilitar el mantenimiento de la unidad de serrado, el soporte de alambre se puede quitar de la plataforma de sierra sin liberar la tensión del alambre.

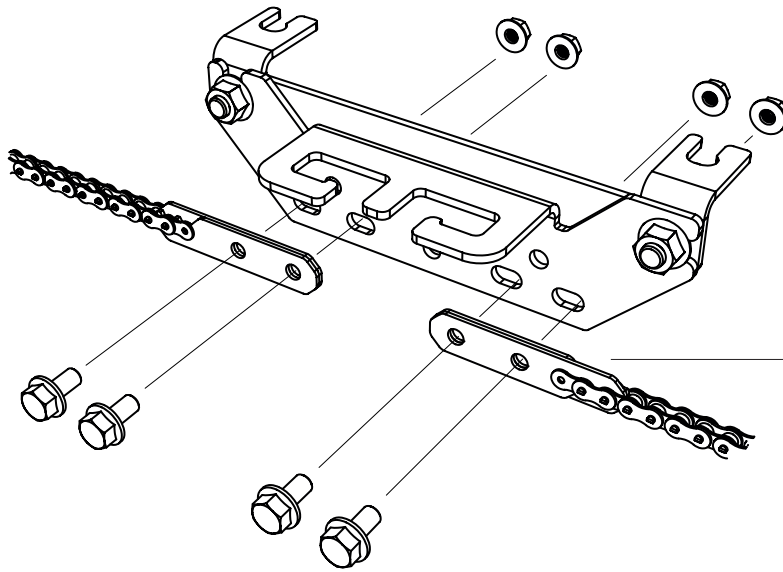
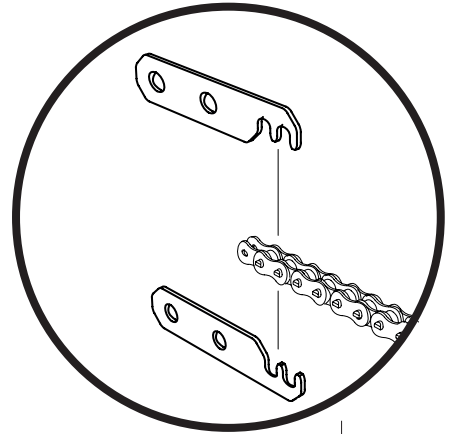

8

-  — 4 x — M6x16
-  — 4 x — M6
-  — 1 x — 01-00697, 4 m
-  — 1 x — 01-00720, 1 m  
Se utiliza para cada ampliación de 1 m



9

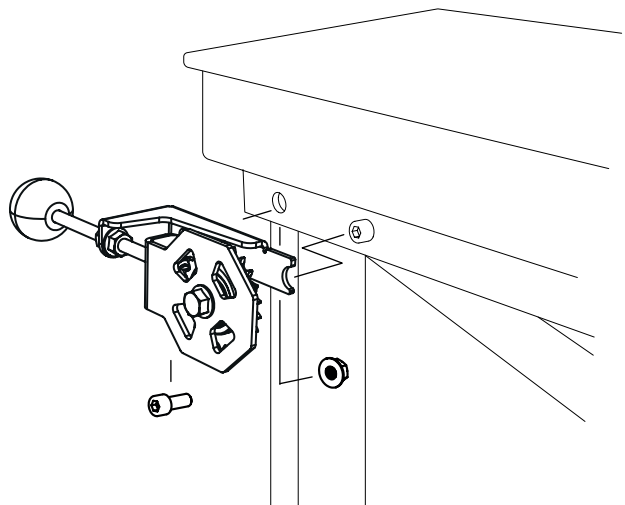

El montaje se lleva a cabo parcialmente utilizando las uniones atornilladas existentes de la barra.

-  — 1 x — M8x20
-  — 1 x — M8



10

El montaje se lleva a cabo parcialmente utilizando las uniones atornilladas existentes de la barra.

-  — 2 x — M8x20
-  — 2 x — M8

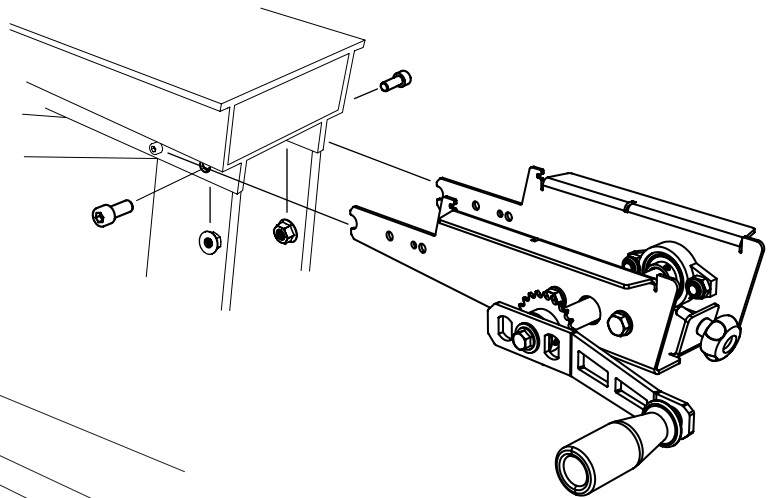

11

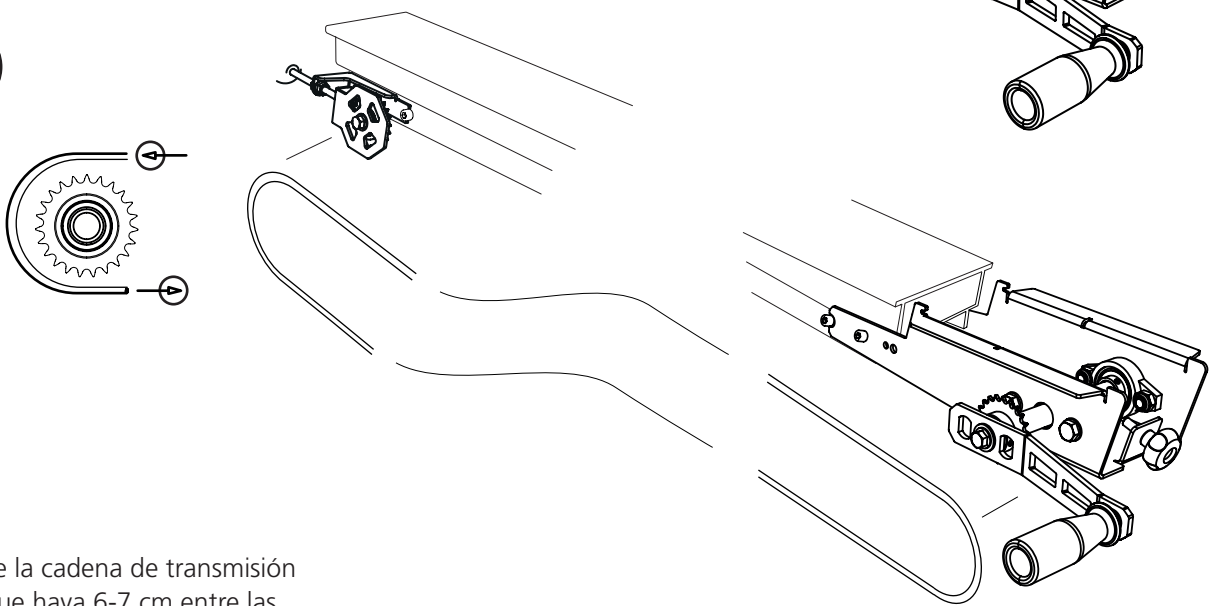

12

Apriete la cadena de transmisión para que haya 6-7 cm entre las cadenas.

Para poder ajustar la tensión, se debe liberar la tuerca con brida del mecanismo de sujeción.

Una vez finalizado el ajuste, asegúrese de volver a apretar la tuerca con brida.

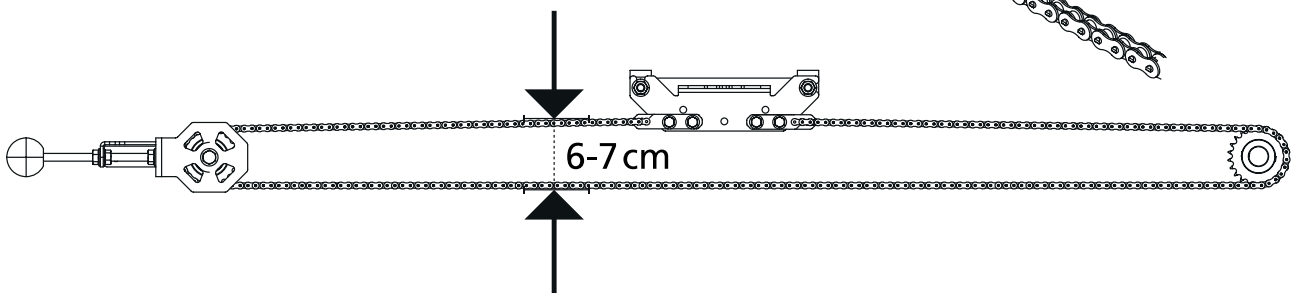
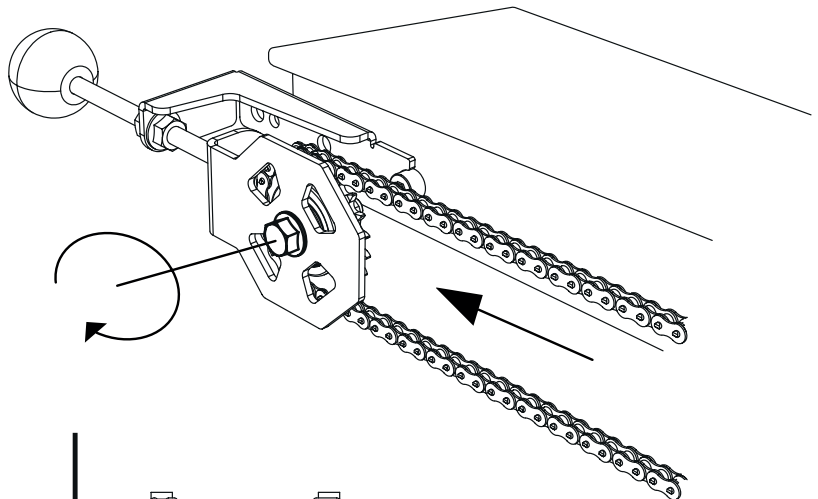

13

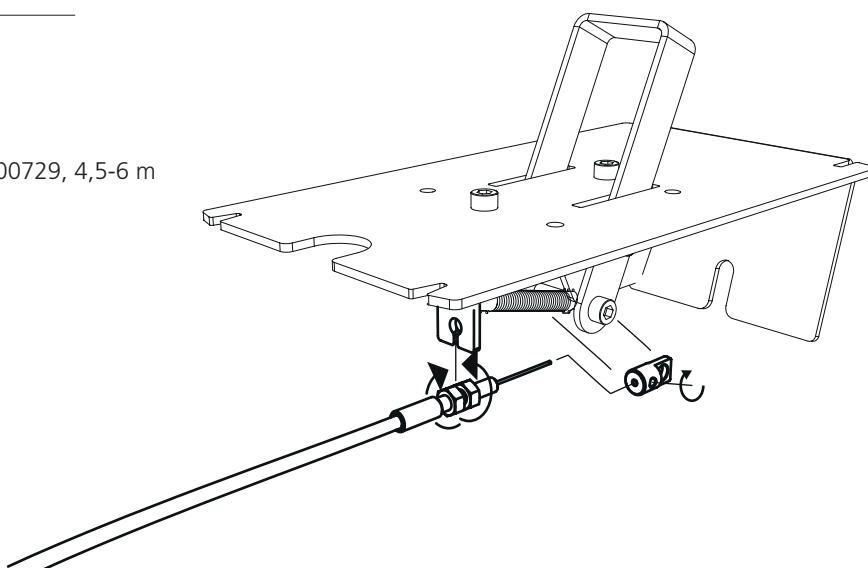
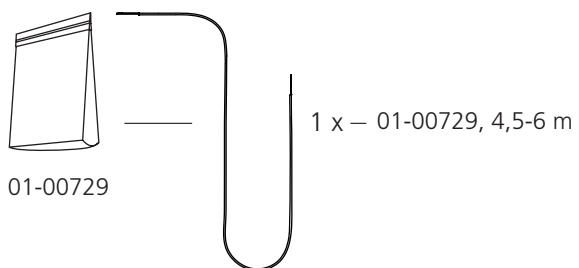
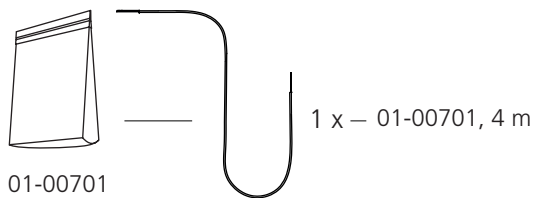

14

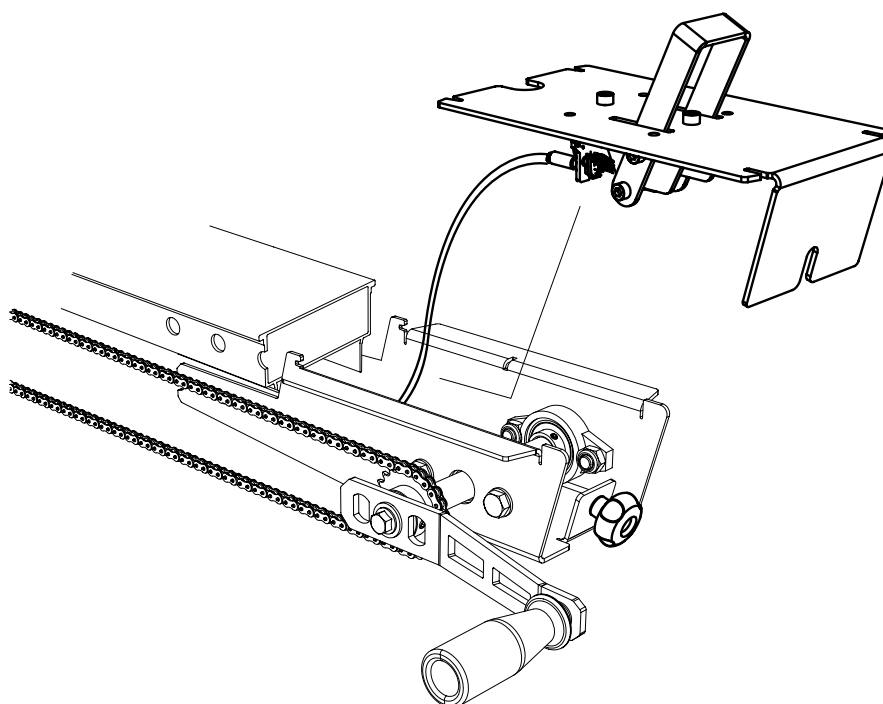

15

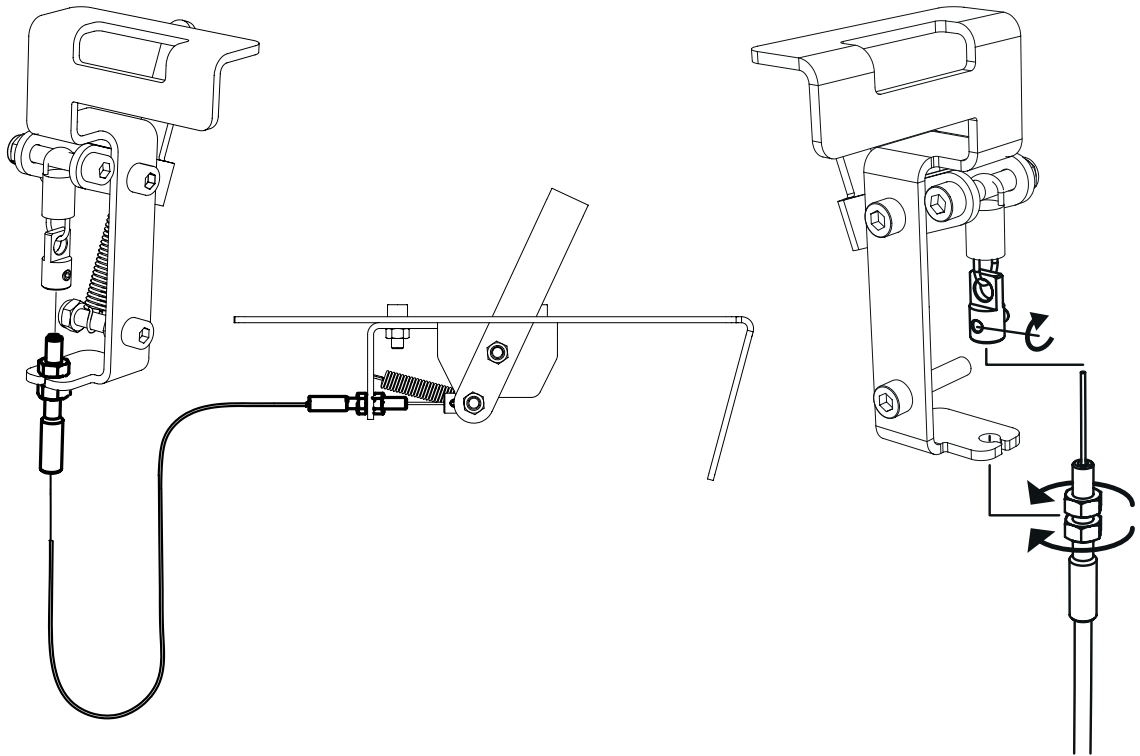

16

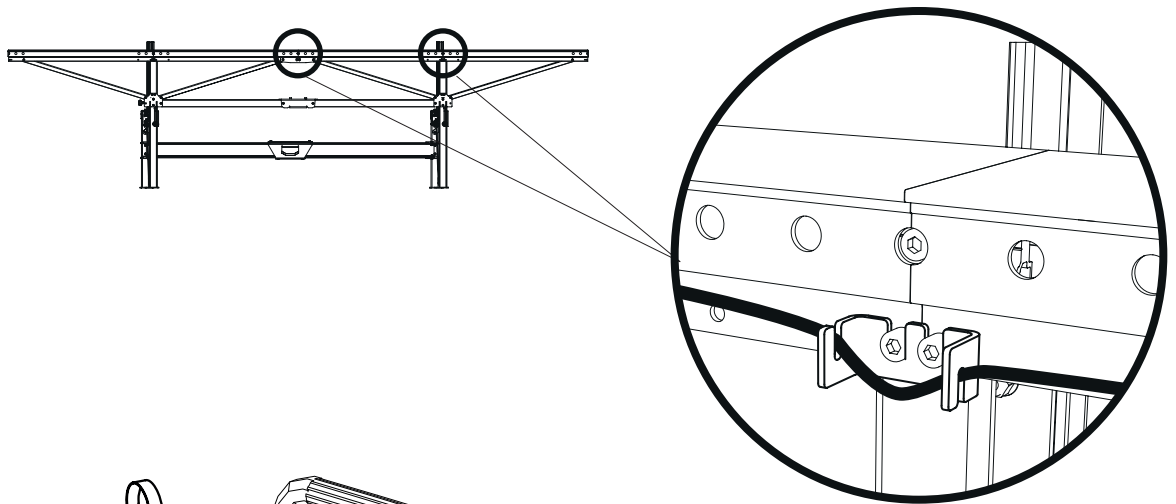

17

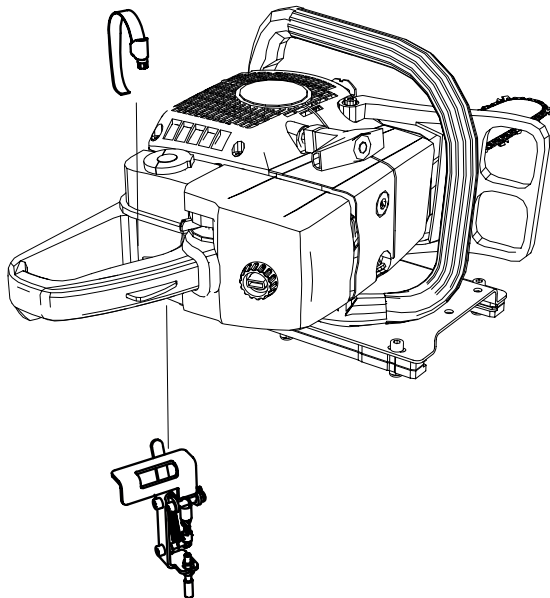

18

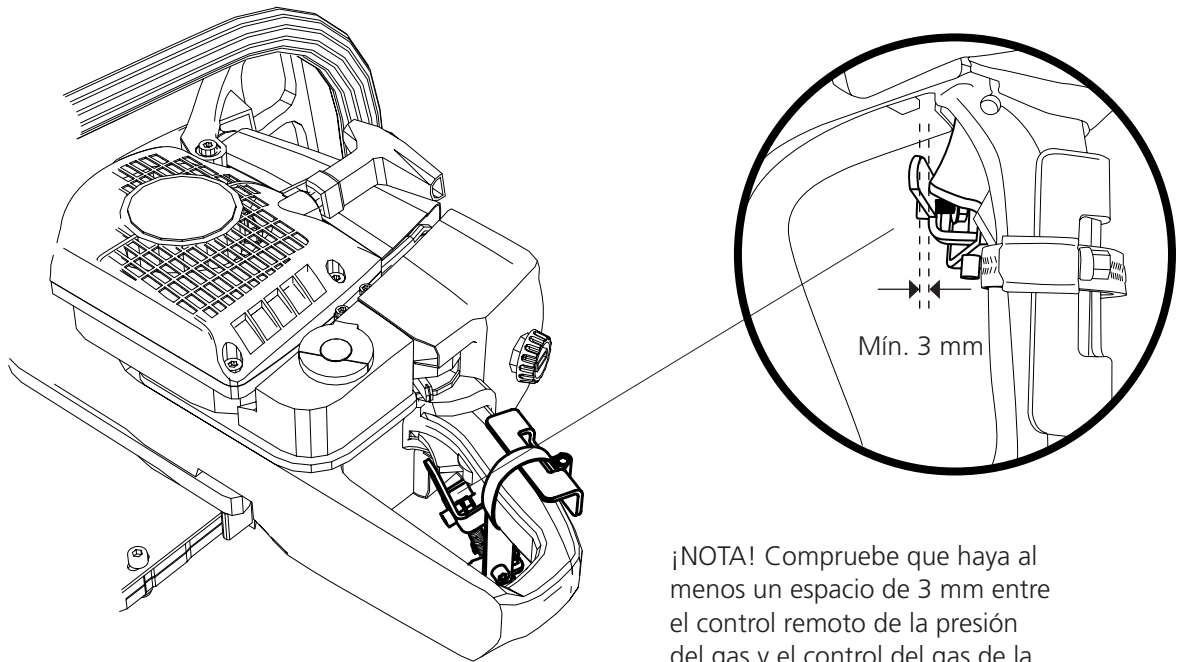

¡NOTA! Compruebe que haya al menos un espacio de 3 mm entre el control remoto de la presión del gas y el control del gas de la motosierra al ralentí.

19

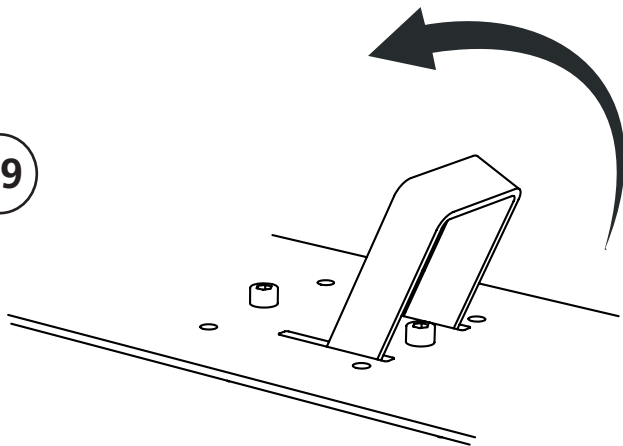

20

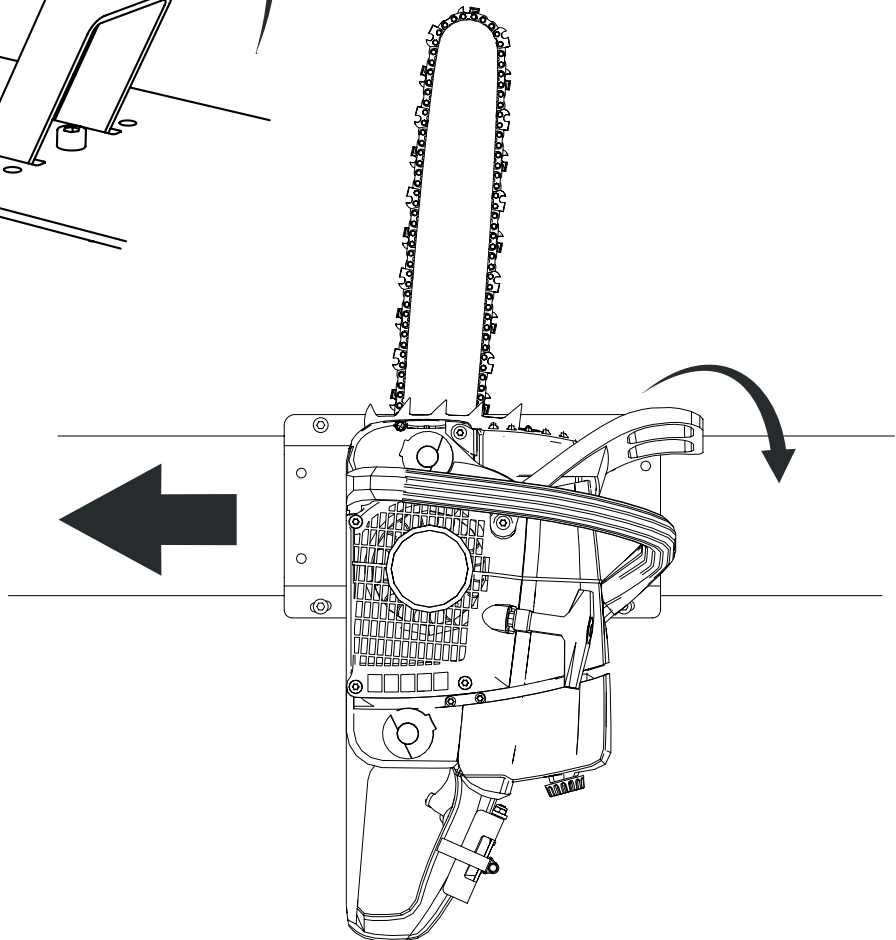



## Declaración de conformidad

De conformidad con la Directiva 2006/42/CE, anexo II, sección A

Logosol AB  
Fiskaregatan 2  
871 33 Härnösand, Suecia,

por la presente declara que **Logosol Alimentación manual de distancia para motosierra**

se ha fabricado de conformidad con:  
la Directiva 2006/42/CE relativa a las máquinas

y se ha fabricado también de conformidad con las  
normas armonizadas relacionadas:  
EN ISO 12100:2010

Fredrik Forssberg, consejero delegado, es el responsable de la documentación técnica.

**En Härnösand, Suecia, a 27 de octubre de 2022.**

**Fredrik Forssberg, consejero delegado**

Fiskaregatan 2, S-871 33 Härnösand, SUECIA  
Teléfono +46 611 18285 | [info@logosol.com](mailto:info@logosol.com) | [www.logosol.com](http://www.logosol.com)