

 **LOGOSOL**

KASUTUSJUHEND

Art nr 0458-395-0717

RED: 2

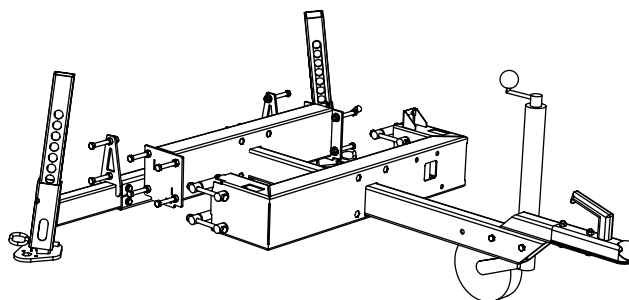
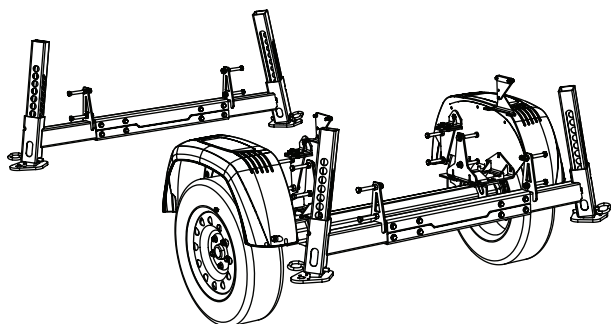

HAAGISEKOMPLEKT TRAILERKIT

1300 KG

B751 PRO / B1001

EE

TÄNAME, ET VALISITE LOGOSOLI MASINA!

Meil on hea meel, et näitate üles usaldust meie vastu, ostes selle masina. Teeme kõik endast oleneva, et vastata teie ootustele.

Logosol on valmistanud saage alates 1989. aastast ja sellest ajast alates tarninud umbes 50 000 masinat rahulolevatele klientidele üle kogu maailma.

Hoolitseme teie ohutuse eest ja ka selle eest, et saavutate masinaga võimalikult hea tulemuse. Seetõttu soovime teil leida aega selleks, et lugeda see kasutusjuhend enne masinaga töötamist korralikult läbi.

Head kasutamist!

Bengt-Olov Byström

Bengt-Olov Byström
asutaja
Logosol Härnösandis



Enne seadme kasutamist lugege kasutusjuhend hoolikalt läbi ja veenduge, et saate kõigest aru.



See kasutusjuhend sisaldab olulisi ohutusjuhiseid.



HOIATUS! Väär kasutamine võib põhjustada kasutajale või teistele inimestele raskeid vigastusi või surma.



LOGOSOL jätkab käimasolevate arendustöödega.
Seetõttu peame jätma endale õiguse muutusteks toodete konstruktsioonis ja disainis.
Dokument: haagisekomplekti kasutusjuhend
Juhendi tootenumber: 0458-395-0680
Tekst: Martin Söderberg
Illustratsioon: Martin Söderberg, Anna Fossane
Viimati muudetud: novembris 2022
© 2023 LOGOSOL, Härnösand, Rootsi

SISUKORD

Ohutusjuhised	4
Komponendid	6
Koostisosad	7
Montaaž	10

OHUTUSJUHISED

- Enne saega tööle asumist lugege hoolikalt läbi kogu käsiraamat. Ohutuseeskirjade eiramine võib olla eluohtlik!
- Veenduge, et kõik saega töötavad isikud on ohtudest täielikult teadlikud ja käsiraamatut lugenud. Käsiraamat peab olema saega töötavatele isikutele alati käepärast. See kehtib ka sae laenamisel ja müümisel.
- Alla 18-aastased isikud ei tohi saagi kasutada.
- Lapsed ja loomad ei tohi töö ajal viibida sae lähedal.
- Pidage kinni ohutuskaugusest, mis on tingitud valju müra ja tera purunemise korral väljapaiskumise ohu tõttu.
- Saega töötav isik peab olema heas vormis, terve ja puhanud. Tehke töö ajal regulaarselt pause. Ärge töötage alkoholi, narkootikumide või ravimite mõju all ega uimases või tähelepanematus olekus.
- Saega töötamise ajal peab nähtavus olema alati hea. Ärge töötage pimedas või kui olete nägemispuudega.
- Veenduge, et teised isikud on kuuldekaugusel, kui peaksite vajama abi.
- Lisavarustuse paigaldamise korral kasutage ainult Logosoli poolt valmistatud või selgesõnaliselt heaks kiidetud tooteid. Muud seadmed võivad põhjustada õnnetusi ja neid ei tohi kasutada. Logosol ütleb lahti igasugusest vastutusest vigastuste või varalise kahju korral, mis on tingitud sae kasutamisest heakskiitmata lisaseadmetega.
- Kandke alati isikukaitsevahendeid. Sobiv riietus on tihedalt istuv üleriietus. Ärge kunagi kandke töö ajal lahtisi rõivaid, mantleid või muud sellist.
- Kandke raudninaga ja torkekindlaid jalatseid, mis tagavad hea haarduvuse. Ärge kandke salli, lipsu, ehteid jms, mis võivad seadmesse kinni jääda.

Sümbolite selgitused



Oma ohutuse tagamiseks lugege tähelepanelikult läbi kogu juhend ja ärge käivitage masinat enne, kuni mõistate selle kogu sisu.



Kandke heakskiidetud kuulmiskaitset ja kaitseprille. Kuulmine võib saada kahjustatud juba pärast lühiajalist kokkupuudet.



Teravad pöörlevad osad. Hoidke sõrmed eemal!









See sümbol tähendab „HOIATUS!“. Olge eriti tähelepanelik, kui seda sümbolit juhendi tekstis kasutatakse.





Sellele sümbolile järgneb käsk. Olge eriti tähelepanelik, kui seda sümbolit juhendi tekstis kasutatakse.

OHUTUSJUHISED

PAIGALDUSKOHT

-  **HOIATUS!** Ärge kunagi käitage sise põlemismootoriga lintsaage suletud või halvasti ventileeritud ruumis. See võib põhjustada surma lämbumise või süsinikoksiidi mürgistuse tõttu.
-  Lintsaie kasutamine ja saeterade käsitsemine peab toimuma täielikus päevavalguses või nõuetekohase töövalgustuse tingimustes.
-  Hoidke töökoht vaba lastest, lemmikloomadest, takistustest, prahist või muudest esemetest, mis võivad masina kasutajat häirida.
-  Valige paigalduskoht, kus aluspind on kõva kattega ja tasane ning kus on palju ruumi lintsaale, palgivirinale ja saematerjalile. Võimaluse korral paigutage lintsaag nii, et saepuru puhutakse operaatori töökohalt eemale. Asetage lintsaag tasasele pinnale, kus masina ümber on takistusteta vaba ruum vähemalt 5 m. Kui lintsaag soovitakse paigaldada statsionaarselt, on soovitatav rööpad iga risttala all toetada tsementsoklitele või puitklotsidele (15 cm × 15 cm).
-  Hoidke töökohal alati kättesaadav ABC-tüüpi käsitulekustuti (min 3 kg).
-  Hoidke töökohal alati saadaval esmaabi täiskomplekt.

SAE TEISALDAMINE

-  **HOIATUS!** Kinnijäämisega seotud vigastuste oht!
-  Masinaosade tõstmise ja liigutamise ajal hoidke inimesed ja lemmikloomad masina ümber olevast 5 m laiusest ohutsoonist eemal. Kinnitage koorem transpordi ajaks.
-  Lintsaagi tohib liigutada ainult siis, kui saepea on kinnitatud pikisuunas rööbastele ja vertikaalsuunas kindlaksmääratud kohas.

Saepea lukustamine: Enne sae teisaldamist kinnitage saepea kaasasoleva mehhanismi abil ettenähtud kohas.

KOMPONENDID

Allpool on kirjeldatud komponente, et teaksite, kuidas osi montaaži ajal nimetada.

(B1001: 02-00366) B751 PRO: —

(B1001: 02-00392) B751 PRO: —

(B1001: 04-00560) B751 PRO: —

30		1	Screw M6SF M8x10 8.8 fzb
29	04-00155	1	GN352 30-15-M8 E55
28	04-00589	1	Coupling head ISO/50 1500kg
27		4	M6SF DIN 6921 M8x25 8.8 fzb
26		2	Screw M6SF DIN 6921 M8x12 8.8 fzb
25		4	Nut LM6MF DIN 6926 M10 8 fzb
24		4	Screw M6S DIN 931 M10x65 8.8 fzb
23		20	Nut M6M ISO 4032 M12 8 fzb
22		20	Nut M6MF DIN 6923 M12 8 fzb
21		20	Screw M6SH ISO 4017 M12x90 8.8 fzb
20		4	Screw M6SF DIN 6921 M12x30 8.8 fzb
19	01-00335	4	Rail connection
18	04-00556	2	Hair Pin Wiberger hns 3
17	04-00557	2	Bolt 12x80 Wiberger sms 2360
16	04-00577	1	Trailer jockey Ø200x50 (ALKO 1224351)
15	04-00576	1	Jockey wheel-clamp (ALKO 01-00)
14	02-00417	1	Crossbunk
13	02-00368	1	Drawbar
12	03-02279	2	Drawbar Bracket Left
11	03-02278	2	Drawbar Bracket Right
10	02-00416	1	Drawbarbeam
9	01-00614	3	Support legs
8	03-02342	1	Spacer
7	03-02344	2	Lower bracket
6	03-02343	2	Upper bracket
5	01-00667	2	Carriage lock-downs
4	01-00737	2	Fender asm
3	02-00494	2	Axle mount
2	04-00559	2	Wheel and rim 155/80 R13 C8 (5x112) 625kg
1	04-00588	1	Wheel axle 1300kg/A760/C1360/112x5
Item no.	Art.no.	Qty.	Description

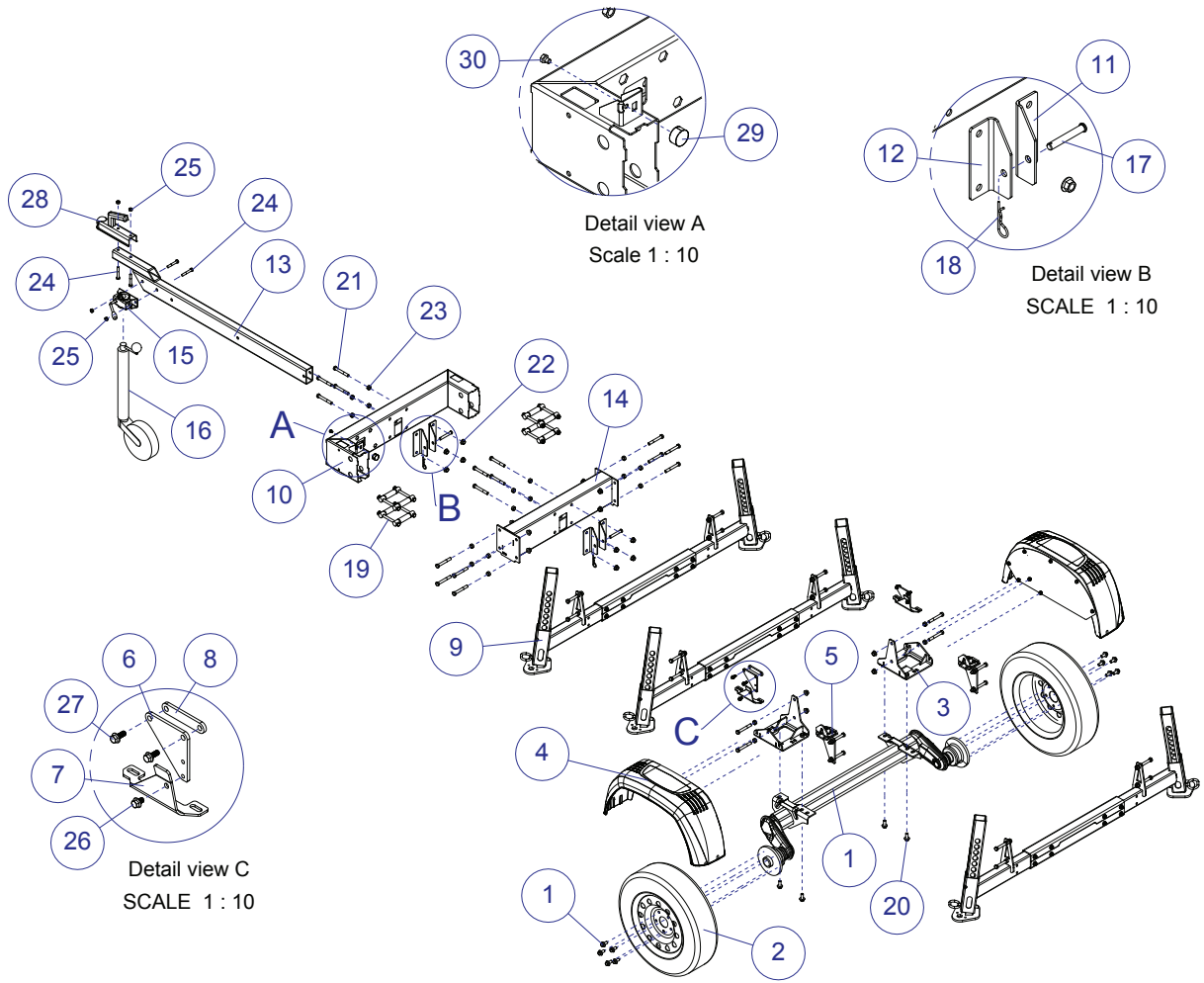

Exploded view



01-00668

Kontrollige, kas kõik osad on tarnitud.

	2 x	03-03160
	2 x	02-00494
	2 x	02-00477
	2 x	03-03008
	2 x	V, 03-02279
	2 x	H, 03-02278
	1 x	04-00576
	2 x	03-03011

	1 x	02-00368
	1 x	02-00392 B1001
	1 x	02-00416 B751 PRO
	1 x	02-00366 B1001
	1 x	02-00417 B751 PRO
	2 x	04-00558
	2 x	04-00559
	1 x	04-00560 B1001
	1 x	04-00588 B751 PRO
	1 x	03-02342
	2 x	03-02343
	2 x	03-02344
	1 x	04-00589
	1 x	1-00668-skp
	1 x	1-00737-skp
	8 x	03-01814
	1 x	04-00577
	1 x	03-03042



8310-001-0050

x3

		2 x – M10x25
		8 x – M10x70
		8 x – M10
		4 x – M12x100 NV18
		4 x – M12
		4 x – M12 NV18

01-00614-skp

02-00475	2 x	
03-03020	2 x	
02-00474	2 x	
04-00549	2 x	



01-00668

	4 x	M12x100
	4 x	M10x65
	20 x	M12x90 NV18
	8 x	M12x140
	2 x	M8x12
	4 x	M8x20
	4 x	M8x25
	4 x	M12x30
	24 x	M12 NV18
	4 x	M10
	24 x	M12
	4 x	M8
	8 x	M12
	2 x	Silindriline polt 12 x 80
	2 x	Vedrusplint

01-00668-skp

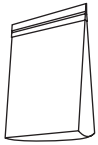

01-00737-skp
2x

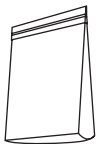

	3 x	M8x16
	5 x	M8
	5 x	M8x16
	5 x	M8
	3 x	M8



8310-001-0110



01-00570

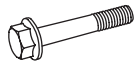

4 x M6x35

03-02649 — 2 x

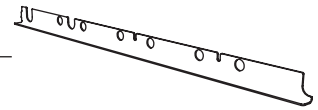

03-02648 — 2 x

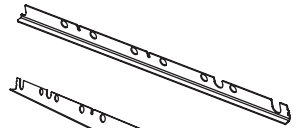

03-02459 — 6 x

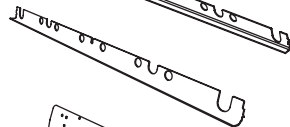

03-02488 — 2 x

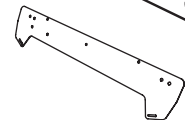

POLT/MUTTER

Kinnitusdetailide määratlus eelmisel lehel.



Seadistuspolts



Ristpeakruvi



Pilupeakruvi



Lukustuskrugi



Kuuskantmutter



Äärikmutter



Lameseib



Kuuskantpeapolt

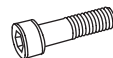

Kuuskantpeapolt
(osaliselt keerrestatud)

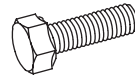

Kuuskantpeakruvi

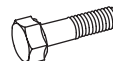

Kuuskantkrugi
(osaliselt keerrestatud)



Äärikruvi

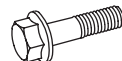

Äärikruvi
(osaliselt keerrestatud)

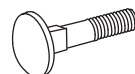

Peitepeaga polt

LISASÜMBOLID

Järgmisi sümboleid kasutatakse ülaltoodud piltide lisana detaili kujunduse kirjeldamiseks.



Madal



Lukustatav polt



Lukustiga mutter



Koonuspeaga



Kübarimutter

MÕÕTMED/PIKKUS

Kinnitusdetailide mõõtmed esitatakse läbimõõduna (M) ISO 68-1. Sellele järgneb kruvide puhul pikkusmõõde; kruvi mõõde on kruvi see osa, mis jääb peast alla poole.

(Läbimõõt)

(Pikkus)

M8

x

20



8310-001-0110

**Alustage montaaži uute
ümberminekukaitsete paigaldamisega.**

Paigaldage uued ümberminekukaitset saepea sõidusiini kinnihoidvate poltidega. Arvestage, et kokkupanek peab algama ja lõppema otsatükkidega.

Olge ettevaatlik, et mitte keerata polte liiga palju lahti, sest mutrid võivad ära kukkuda.

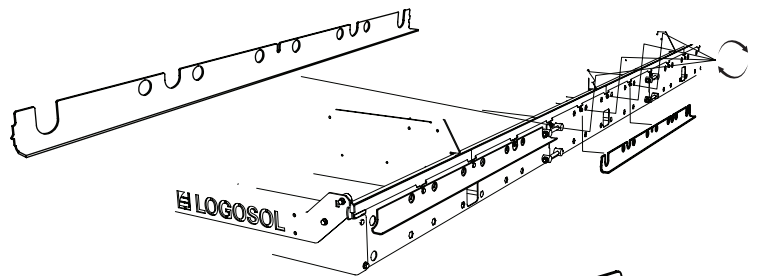
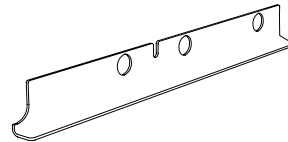
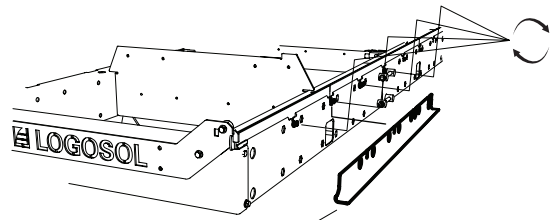

Paigaldage saepea rattad ümberminekukaitseplaadile. Kasutage komplektis sisalduvaid seibe ja mutreid.



1 x 01-00570

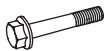

2 x M6x35

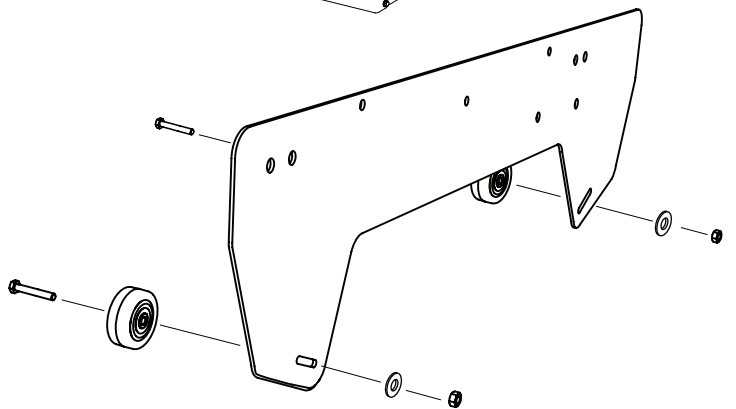

Paigaldage saepea lukk kelgu torule. Olemasolevad mutrid vahetatakse välja tooteartiklite 03-03011 vastu. Seejärel korrake montaaži teisel saekelgu torul.



2 x 03-03011

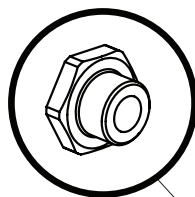

Tuleb kasutada sae olemasolevaid kruvisid.



4 x M10



4 x M8

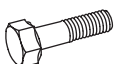

6 x M8x95

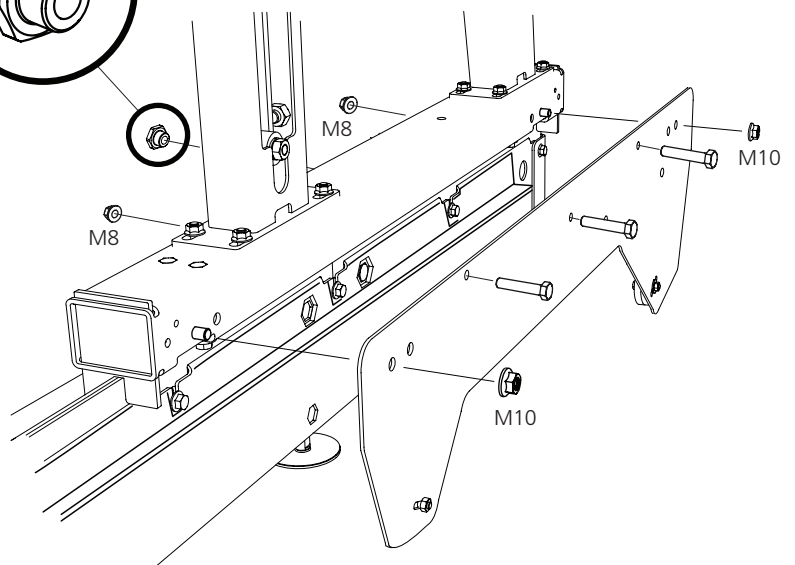



8310-001-0110

Tõstke juhtrelss ohutult üles nii, et relside alumine külg oleks maapinnast 400 mm kõrgusel. See on madalaim kõrgus, mis võimaldab tugijalgade paigaldamist.

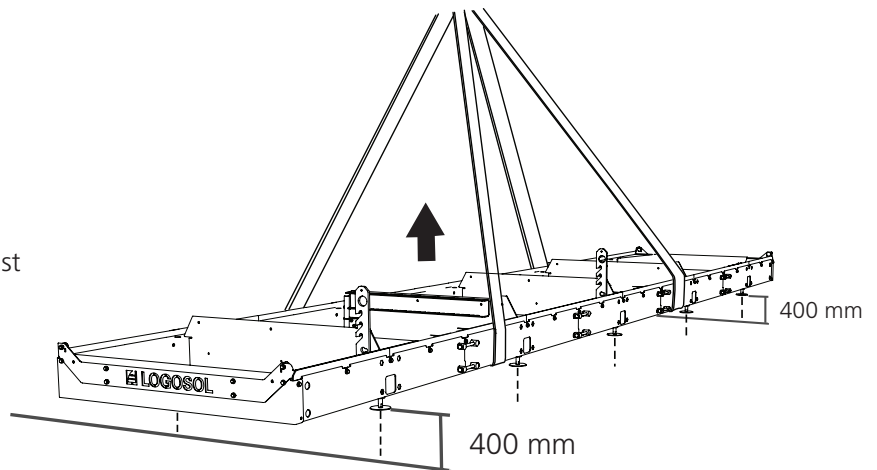

Standardversioon koos haagisekomplektiga.

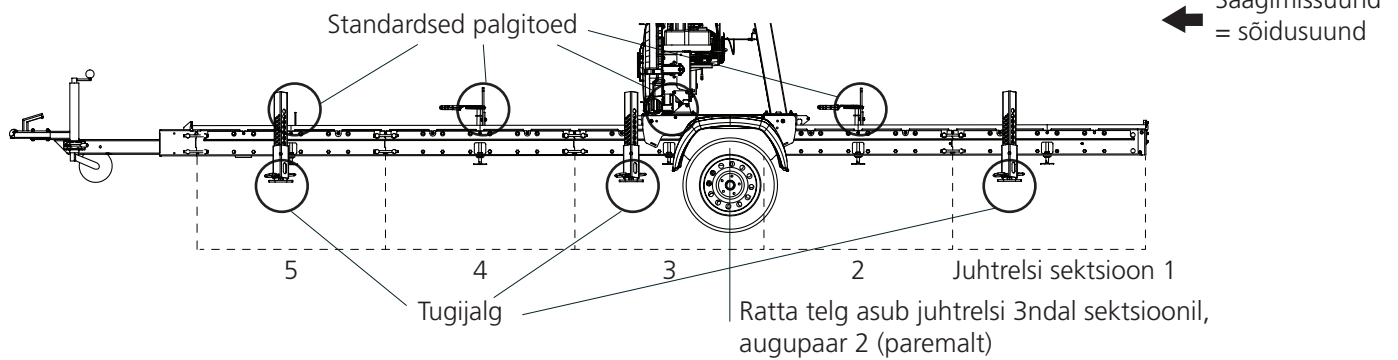

Standardversioon haagisekomplekti, hüdraulika ja pikendusega (mis on maksimaalne juhtrelsside arv hüdraulikaga).

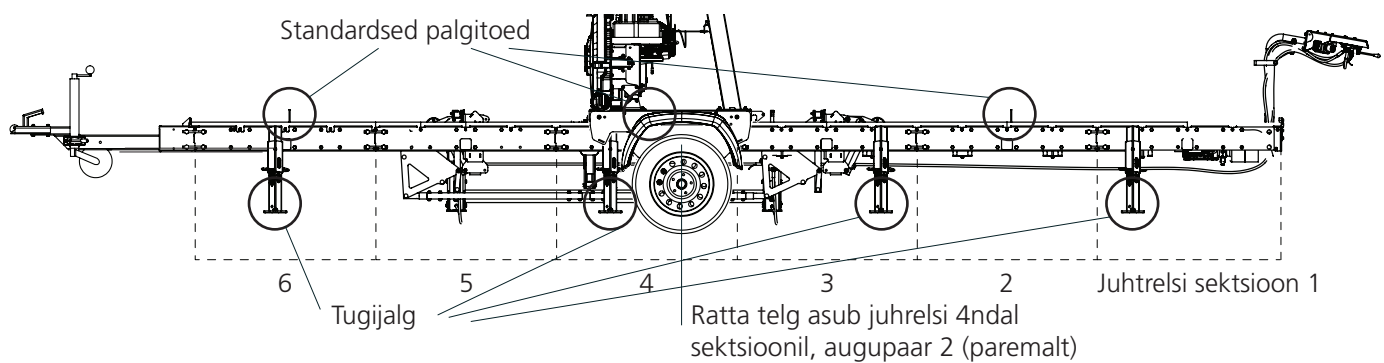

Standardversioon koos haagisekomplekti ja kahe pikendusega (see on maksimaalne arv)

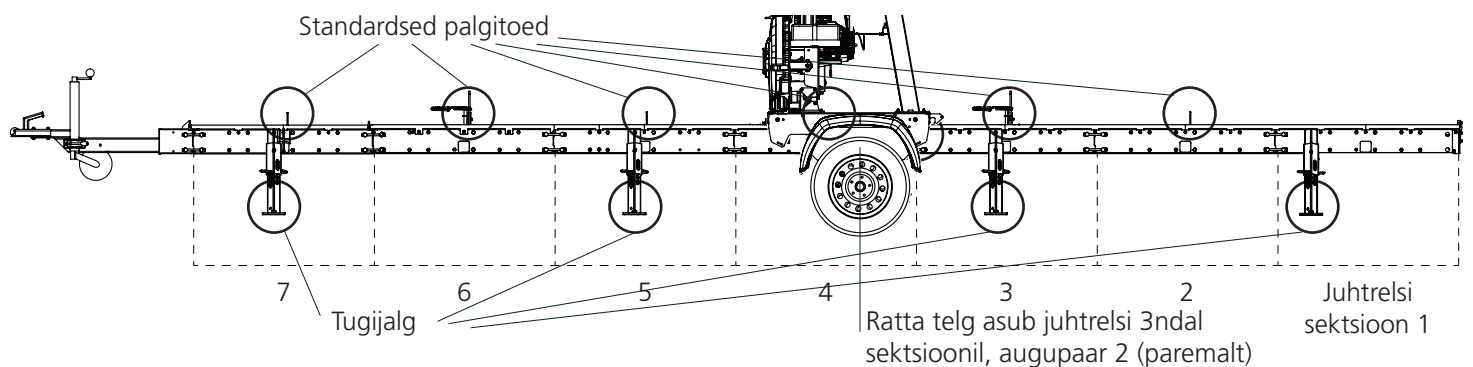



8310-001-0050

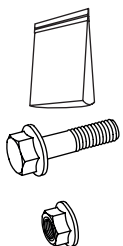

1 x - 01-00614-skp

8 x - M10x70

8 x - M10

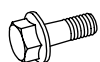
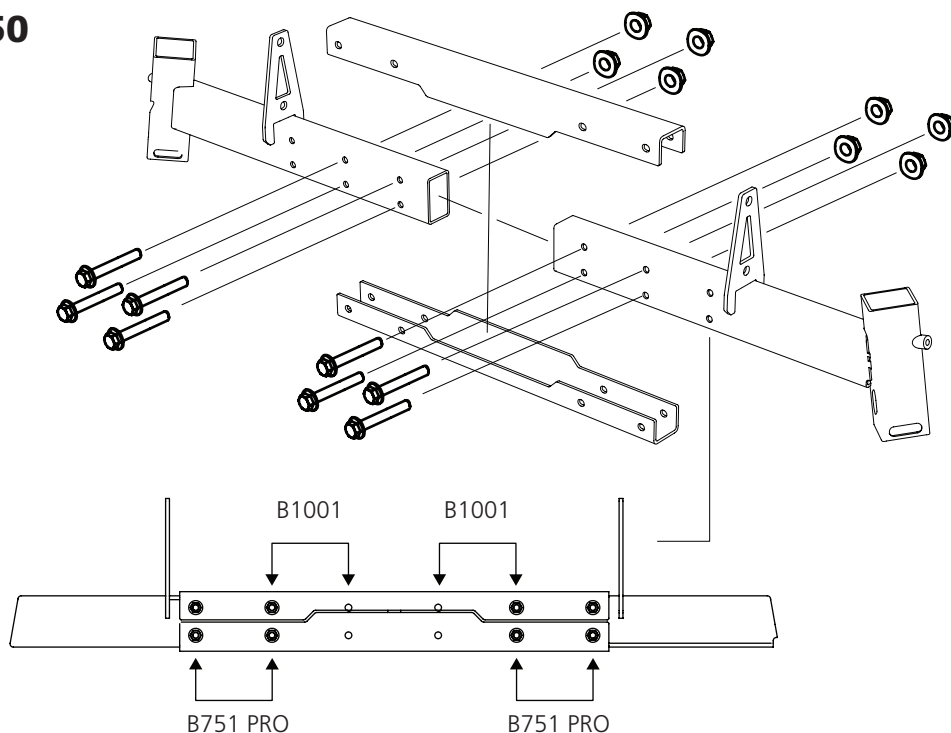

2 x - M10x25

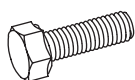
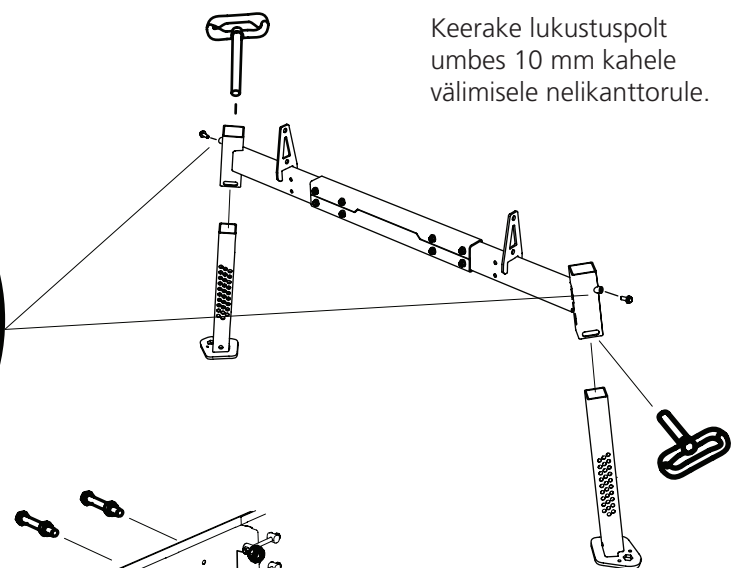
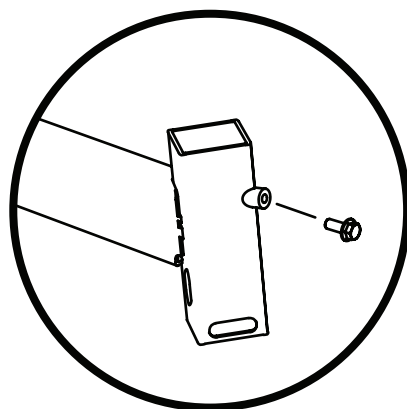

4 x - M12x100 NV 18



4 x - M12



4 x - M12

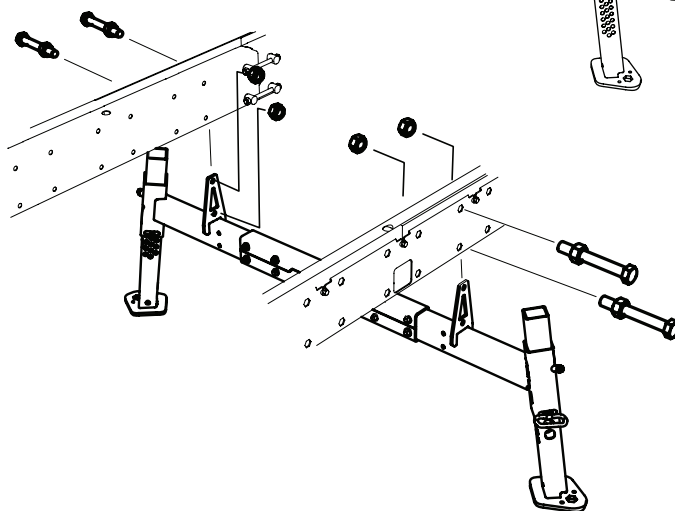



01-00668



1 x - 01-00668-skp

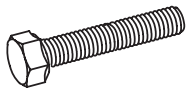

20 x M12x90 NV18



20 x M12 NV18

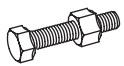

4 x



4 x M12

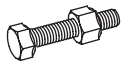

4 x



4 x M12



Kasutatakse saega kaasas olnud osi.



1 x M8x10



1 x

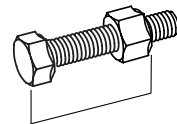
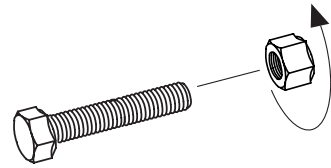

78,5mm

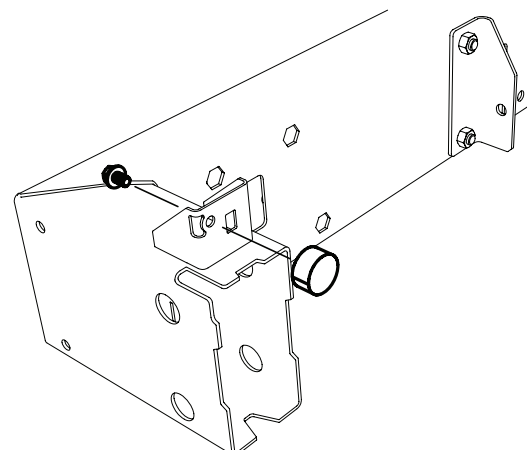
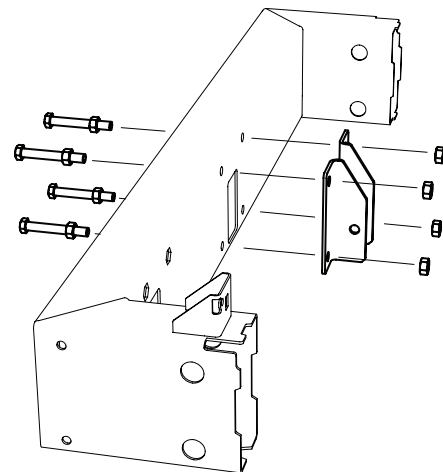
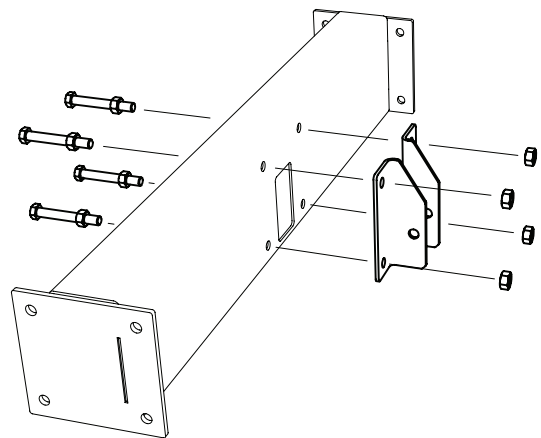



01-00668

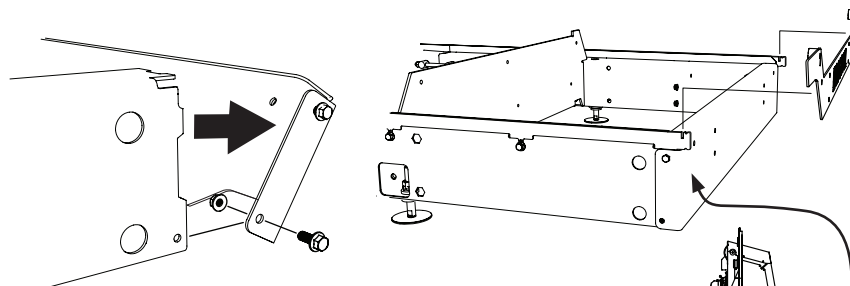

Demonteerige otsaplaat ja otsatükk juhtsiini otsast. Arvestage, et haagisekomplekti veetiislid tuleb sae suunas vaadates paigaldada juhtsiini otsa.

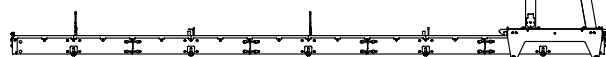

Paigaldage tugevdus esimesele augupaarile juhtsiini otsast. Keerake ühendus näppudega kinni.

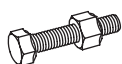
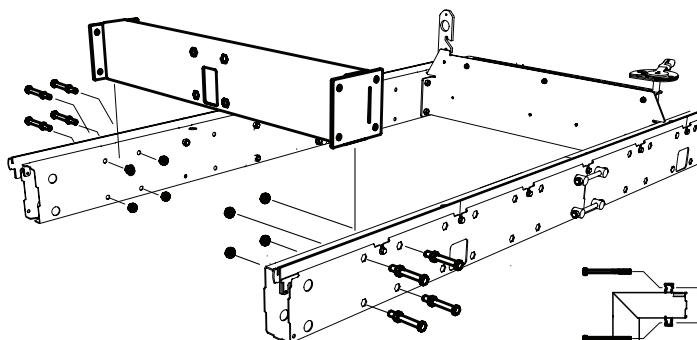

8 x



8 x M12

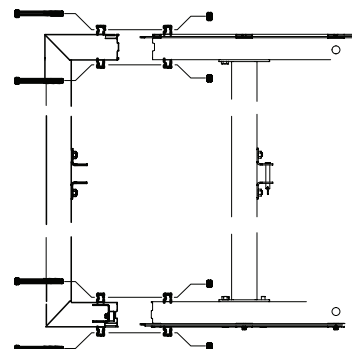

Paigaldage välimine veetiisel juhtsiini otsale. Paigaldage jätkud ja tõmmake neid seejärel vaheldumisi sisse- ja väljapoole, kuni juhtsiini otsad sobivad üksteisega. Hea sobivuse saavutamisel pingutatakse nii sisemise kui ka välimise poolt korraga.

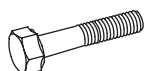
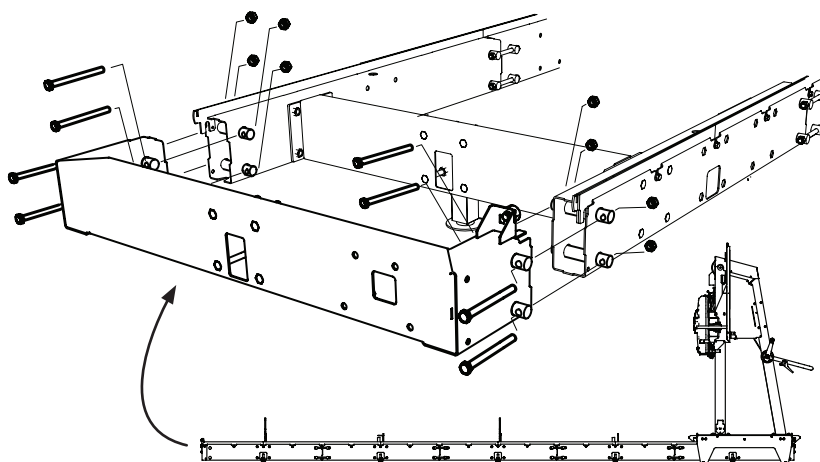

8 x M12x140



8 x M12

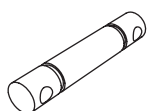

8 x

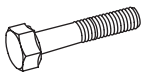
**01-00668**

4 x

M10x65



4 x

M10

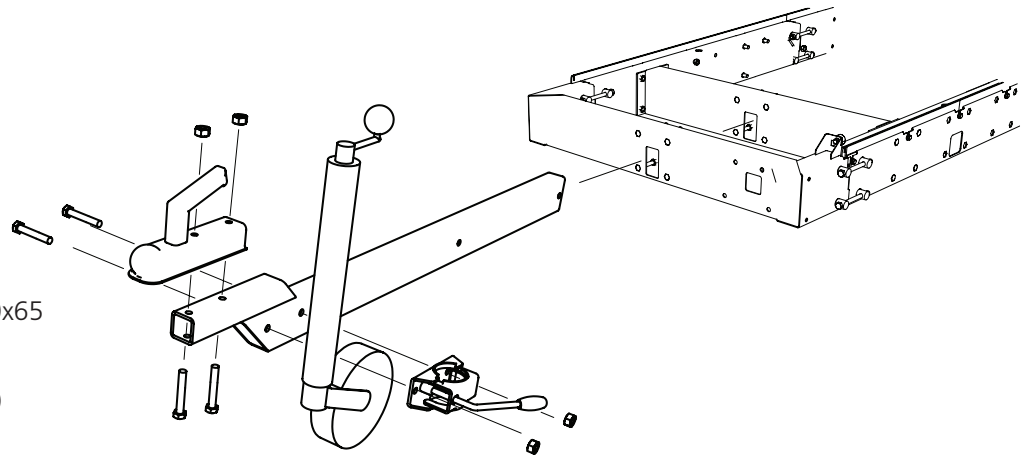

2x

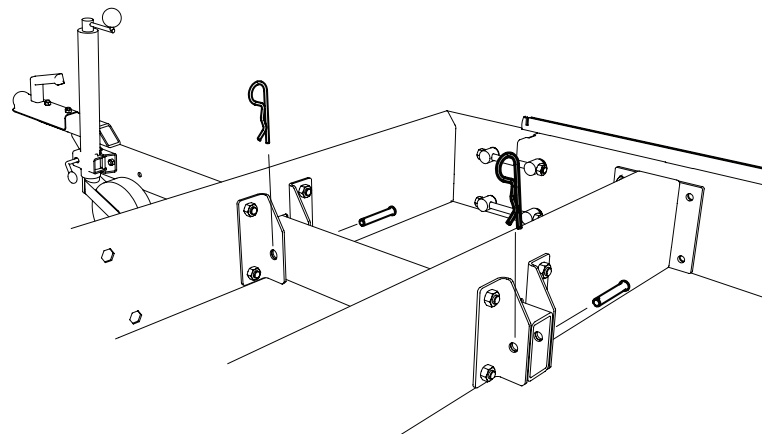

2x

**VEOTIISLI ASUKOHT**

Käru veotiisel tuleb transportimiseks asetada välimisse asendisse. Veotiisli võib saagimise ajaks eemaldada, kui seda peetakse häirivaks.

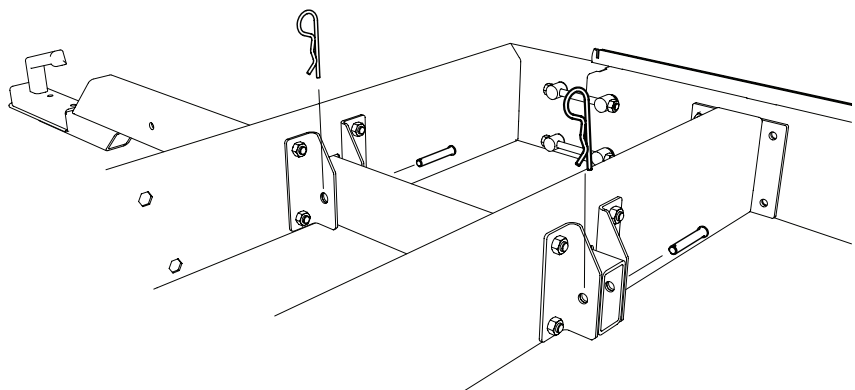

10

Paigaldage ratta teljekinnitused juhtsiinide alla. Paigaldamisel pange tähele pikisuunalist paigutust juhtsiinidel. Kinnitused paigaldatakse kolmandale juhtsiinile augupaarile 2.

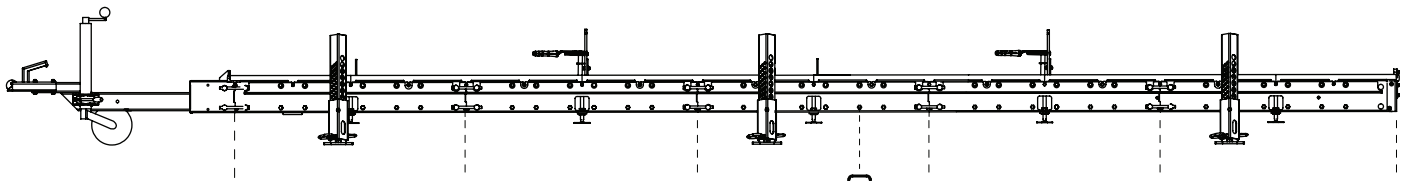
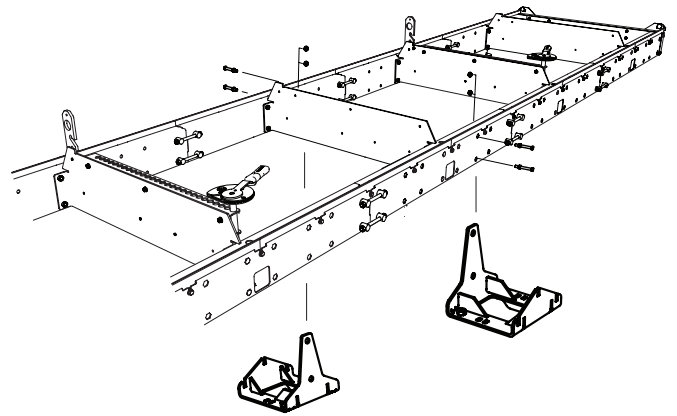
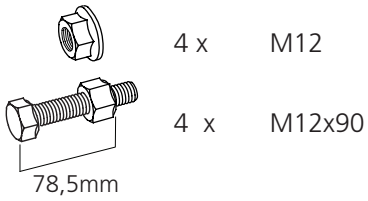

11

Porilaudade paigaldamisel pange tähele, et need tuleb paigutada nii paremale kui ka vasakule.

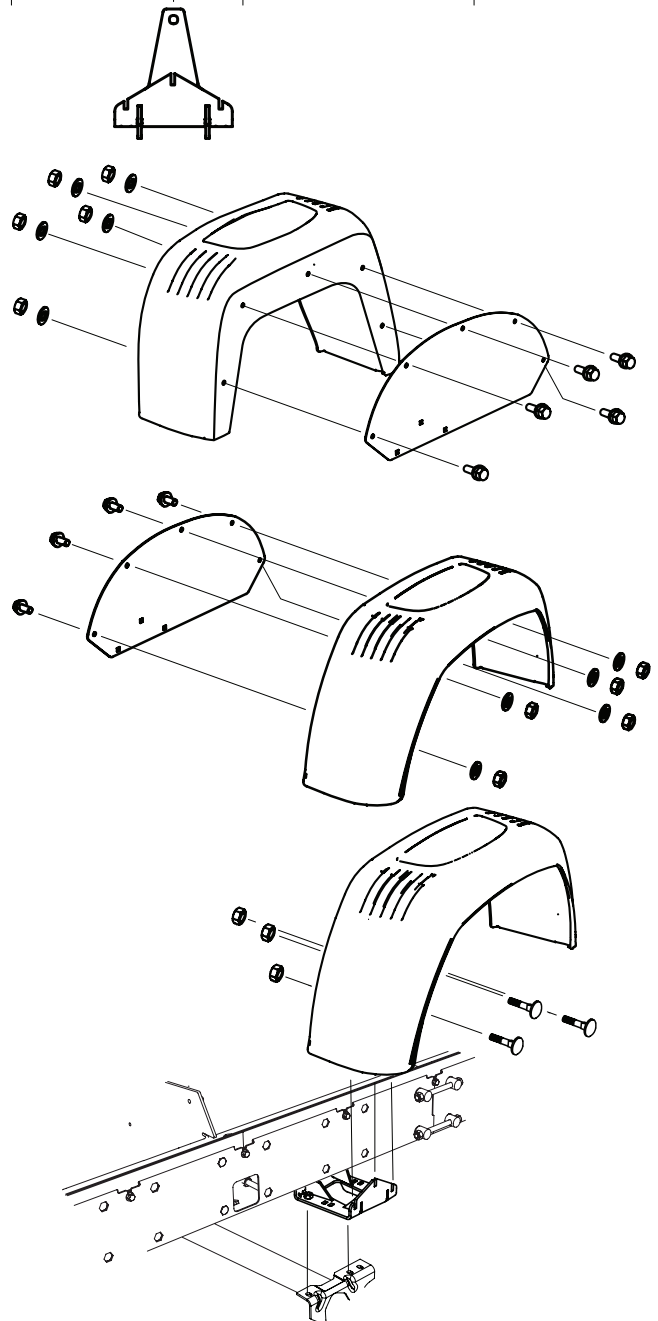
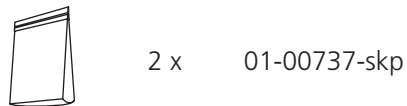



01-00668

12

Paigaldage plaadid saepea lukustamiseks püsttorudele. Võtke arvesse, et saepea väljalaskepoolsele küljele tuleb lukustusplaadi ja püsttoru vahele paigaldada vahetükk.

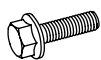
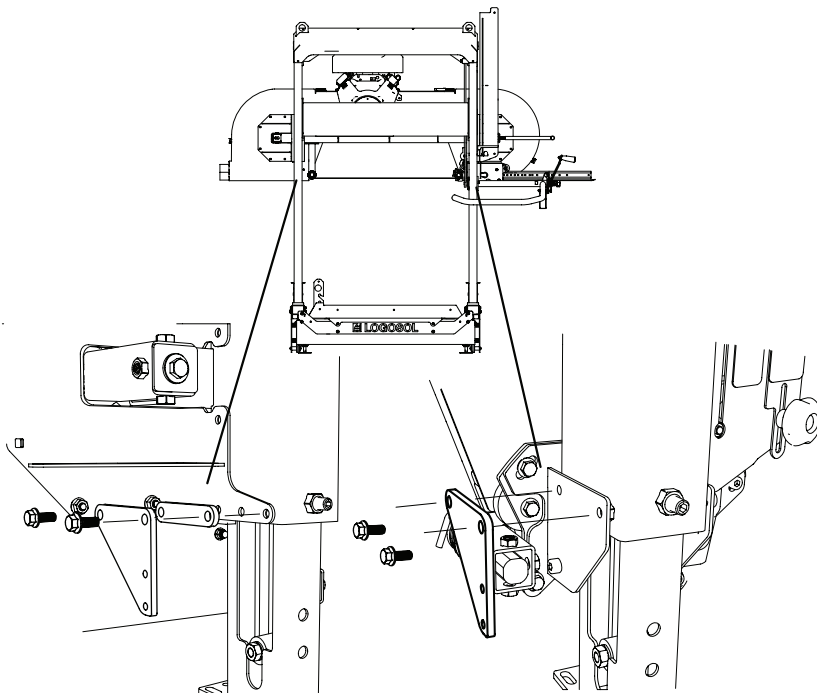

4 x M8x25

13

Saepea lukustamiseks ettenähtud plaadid paigaldatakse vastavate püsttorude põhjaplaadile. Olge poltliidete lahti keeramisel ettevaatlik, sest poltidel on lihtne alumisel küljel olevast torust välja kukkuda. Kasutatakse olemasolevaid mutreid/polte.

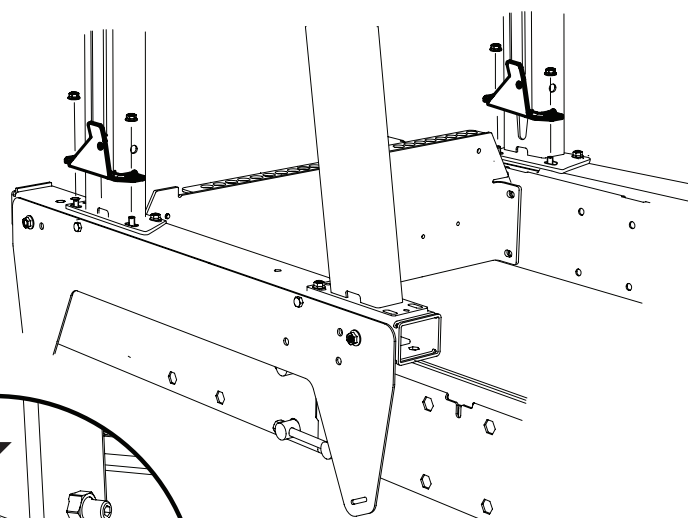

4 x M8

14

Transportimise ajaks lukustatakse lukustusplaadi poltidega.

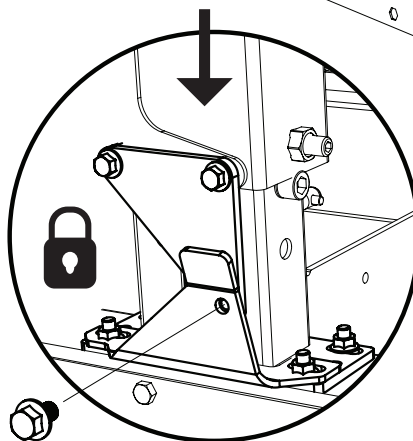

2 x M8x12

15

Paigaldage rattatelg juhtsiini alla. Paigaldamisel pange tähele rattatelje kinnituste pikisuunalist paigutust juhtsiinil.

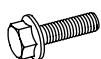
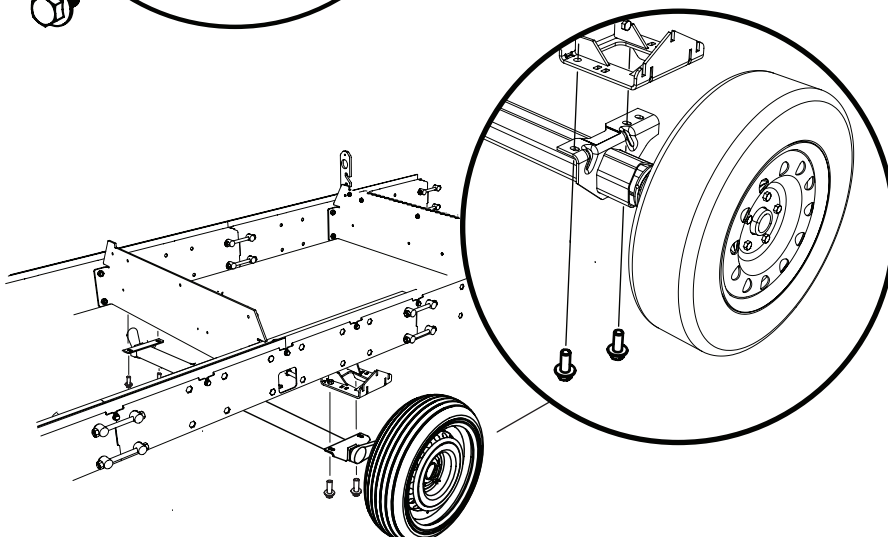

4 x M12x30



01-00668

16

4 x M12x100



4 x M12

17

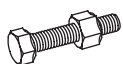

4 x



4 x M12

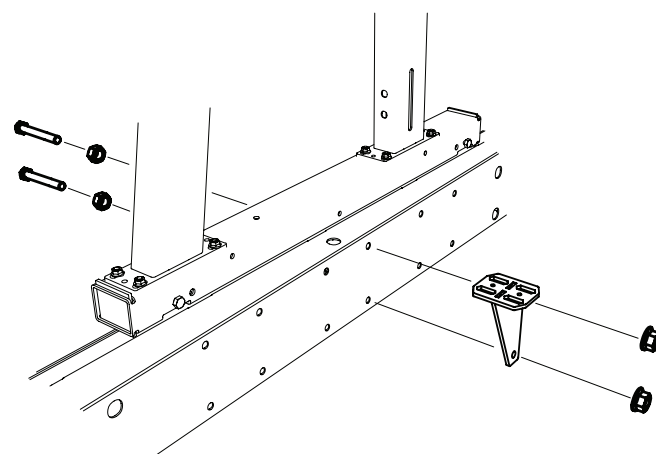
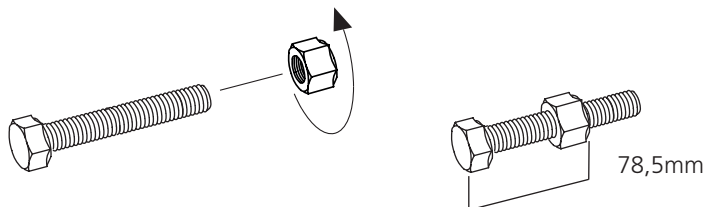

18

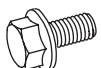

4 x M8x20



4 x M8

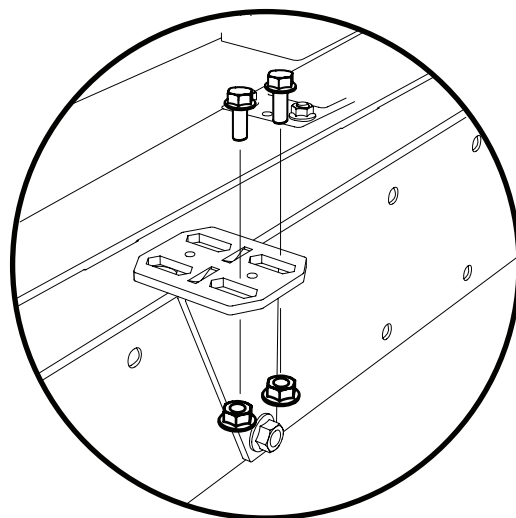

19

1. Transpordiasend:
Transpordi ajaks paigaldage saepea lukustamiseks ettenähtud lukustid vastavate püsttorude plaadile.

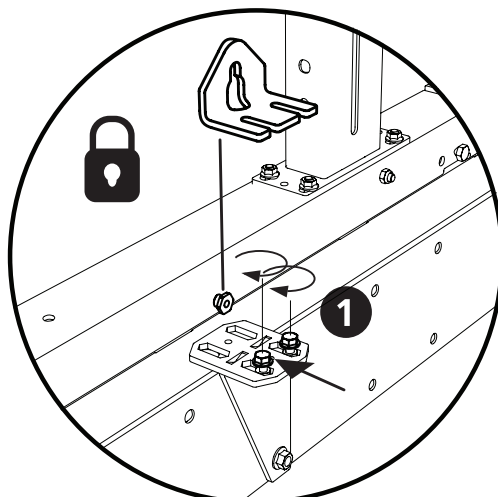

2. Tööasend:
Sae kasutamise ajal paigutatakse liitmik nii nagu on näidatud pildil.

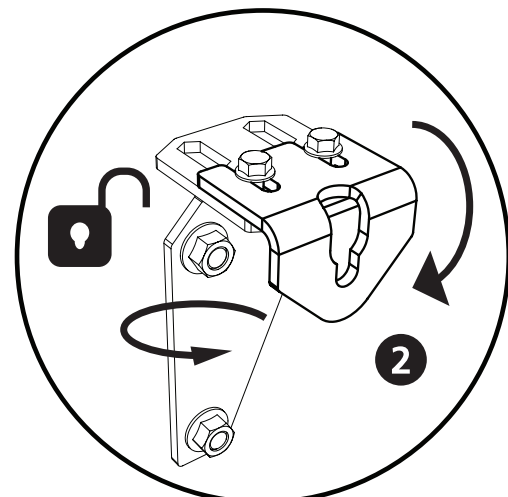

JUHTSIINI REGULEERIMINE

Lintsaeraami hea toimimise tagamiseks on oluline, et see oleks loodis. Juhtsiini reguleerimist alusta küljelt küljele. Asetage saag nii, et rattad oleksid ühes tasapinnas, kontrollides seda vesiloodi abil. Seejärel reguleerige veotiisli tugiratas välja nii, et palgjalus oleks horisontaalne ka pikisuunas. Seejärel laske tugijalad alla ja vajaduse korral tehke neile peenreguleerimine.

Nõuanne! Saagige välja kettad distantsklotsideks tugijalgade alla, kui aluspinnal ebatasasused on suuremad tugijalgade käigust.

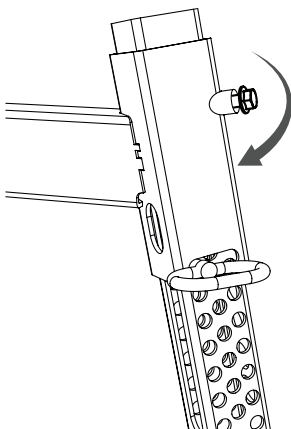
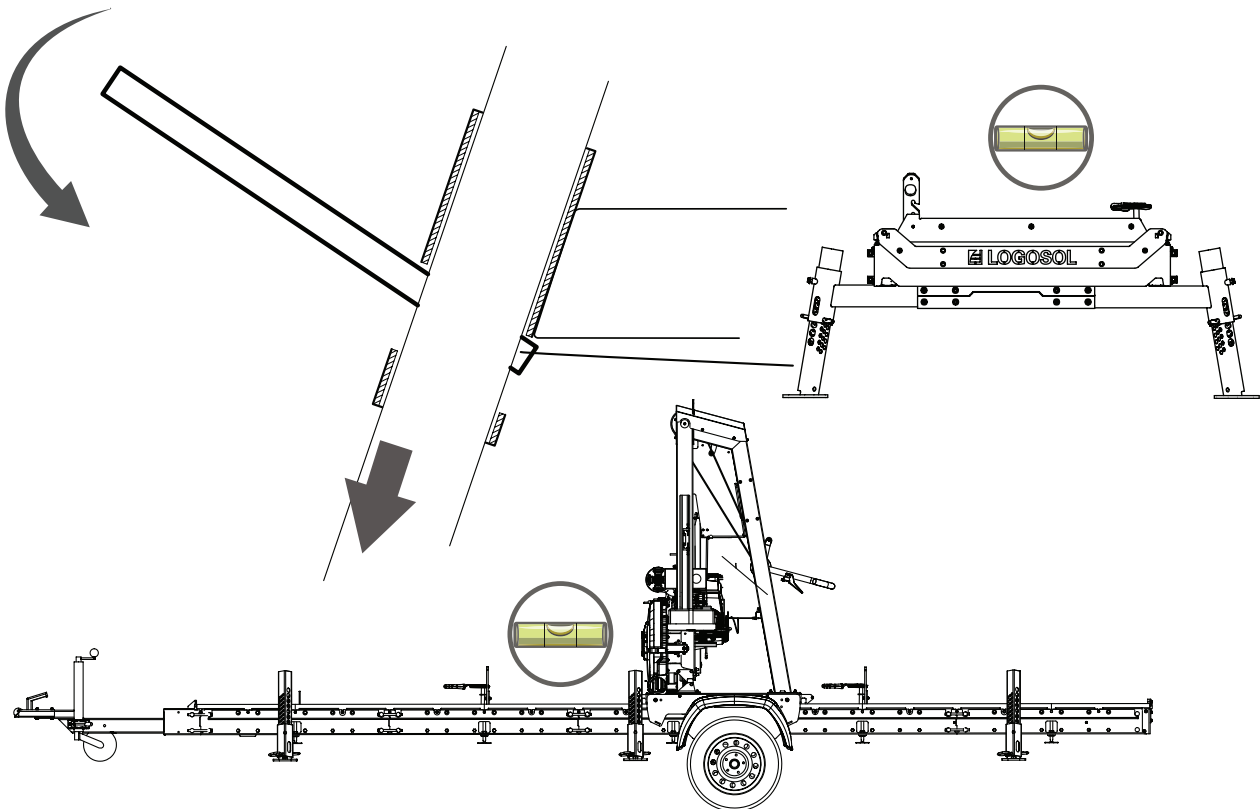
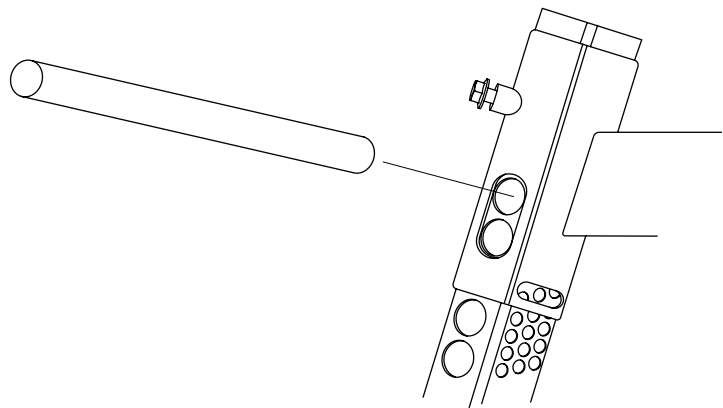

Lõpetage lukustuspoldi pingutamise ja stabiliseerida tugijalg valitud asendis. Ärge unustage seda teha ka transpordi ajaks.



Vastavusdeklaratsioon

direktiivi 2006/42/EÜ lisa 2A kohaselt

Logosol AB
Fiskaregatan 2
871 33 Härnösand

kinnitab käesolevaga, et **Logosoli haagisekomplekt
1300 kg B751 PRO / B1001 jaoks**

on valmistatud kooskõlas järgmisega:
masinadirektiiv 2006/42/EÜ

ja on valmistatud kooskõlas alljärgnevate ühtlustatud
standarditega:
EN ISO 12100:2010

Tehnilise dokumentatsiooni eest vastutab tegevjuht
Fredrik Forssberg.

Härnösand, 23.11.2022

Fredrik Forssberg, tegevjuht

LOGOSOL

Fiskaregatan 2, S-871 33 Härnösand, SWEDEN
Phone +46 611 18285 | info@logosol.com | www.logosol.com