

How to build
your Sauno
kiln dryer

How to build your Sauno kiln dryer

The following description shows our recommendation how to build an efficient low price kiln dryer for indoor or outdoor use. We are here showing how to make a chamber that will fit for Sauno VT 3, but the description is universal and can be used for any size of kiln.

The kiln should be made entirely from stiff polystyrene insulation board, 50 mm thick, and our special screws. The polystyrene board with butt edges (without edge profile) can be ordered from building material stores. It must be a high quality insulation board with closed cells, low water absorption and skin surface. We recommend Dow Solimate, 300 BE.A.N, Paroc Ecoprim 957-00 or similar insulation boards with compressive strength of about 300kN/m² (0,3N/mm²) or more. The boards are normally 1200 x 600 mm or 2400 x 600 mm. If it is possible, try to find big boards. It will work with smaller boards, but it will take more time to build the kiln.

The screws are nylon screws, especially made for this purpose. You can order them with the aggregate.

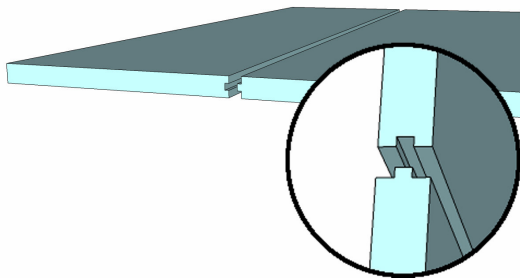

Start to glue the insulation boards together to sheets that are big enough to form the floor, the roof, the sidewalls and the door. Make groove and tongue to assure that the joints are strong and tight. Use expanding polyurethane glue like Casco 1809 or similar.

The back side can be completed when you assemble the kiln.



Cut the sheets to correct sizes. Straight and even cuts are necessary to make sure that the kiln will be tight.



Mould rebates on roof, door, sill and sidewalls of the kiln.

- The roof shall only have a 25 x 25 mm rebate on the front edge. Save 25 mm on each side.
- The door sill shall only have a 25 x 25 mm rebate along the upper inside.
- The sidewalls shall only have a 25 x 25 mm rebate on the inner part of the front edge. Save 25 mm for the roof and 125 mm for the door sill. (See picture below)
- The door shall have 25 x 25 mm rebate on the outside of the lower edge. The side edges and the upper edge shall also have a 25 x 25 mm rebate but on the inside of the door.

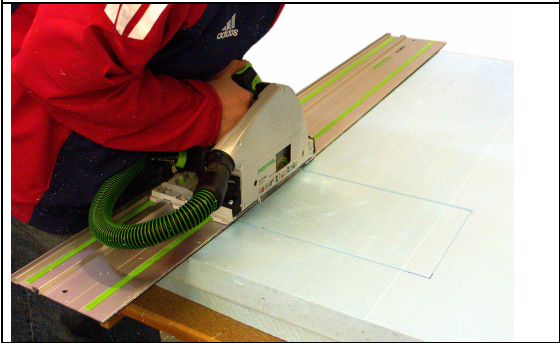
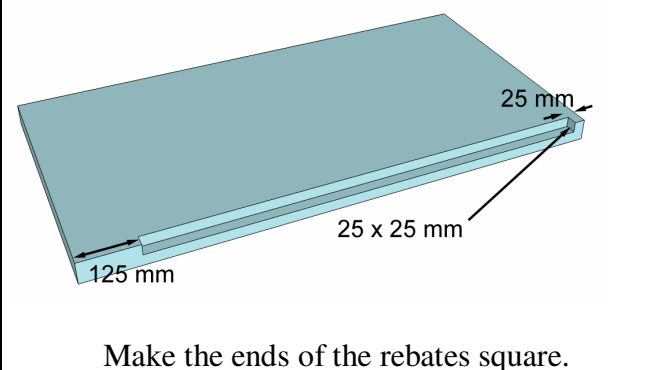

Make openings for aggregate and ventilation valves according to the pictures below. The openings are, as you can see, a few mm wider than the object.

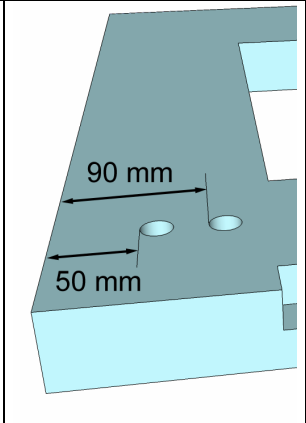
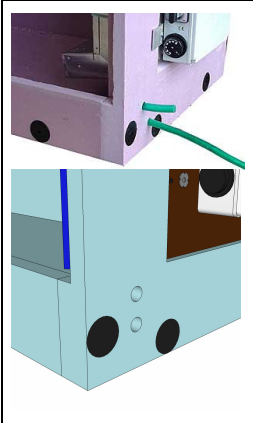
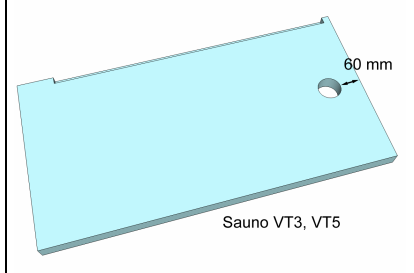
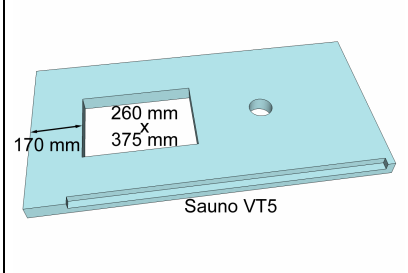
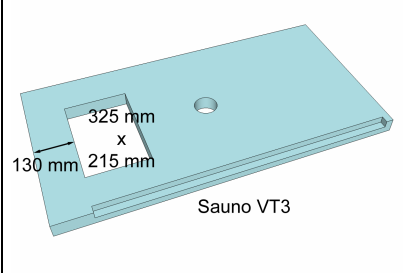

The kiln shall be equipped with two drains. One overflow drain about 50 mm over the floor and one drain on the floor level. The simplest solution is to drill two holes with a diameter of about 20 mm and equip the holes with a fitting plug. You can also make just one hole on the floor level and connect a hose. When the opening of that hose is placed about 40 mm over the floor it will work as an overflow drain.

Gluing the joints with polyurethane glue guarantees that the kiln will be waterproof, but it is also quite sufficient to cement the joints from the inside of the kiln. This method is an advantage if you need the opportunity to demount the kiln.

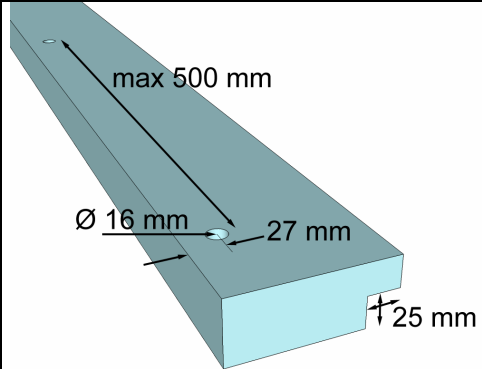
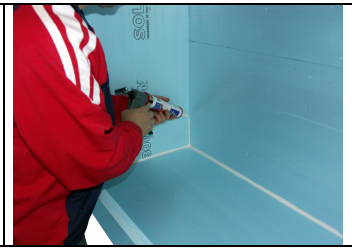

Mark the positions of the nylon screws and make the holes $\text{Ø } 16 \text{ mm}$ (+/-1mm) with a router.

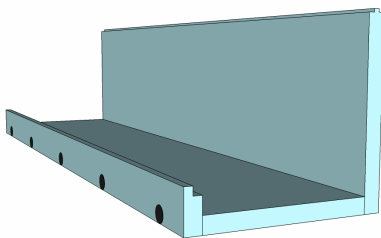

Screw the sill and the back wall to the floor.

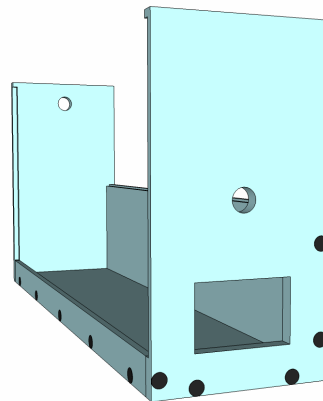

Add the sidewalls.

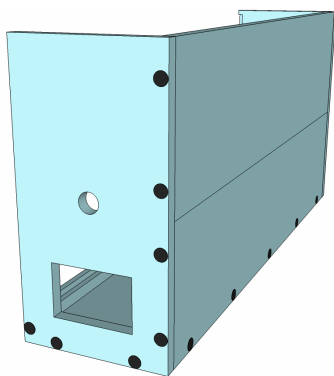

Complete the back wall.

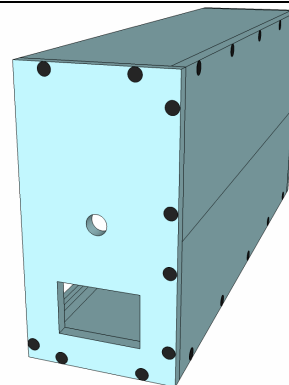

Install the roof.

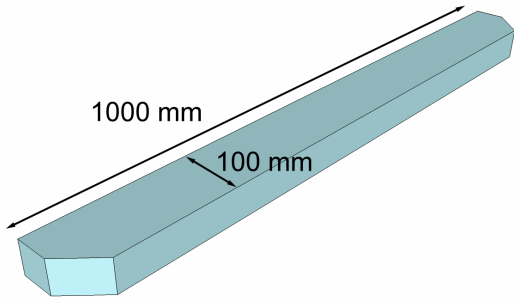

Make the handles from left over pieces.

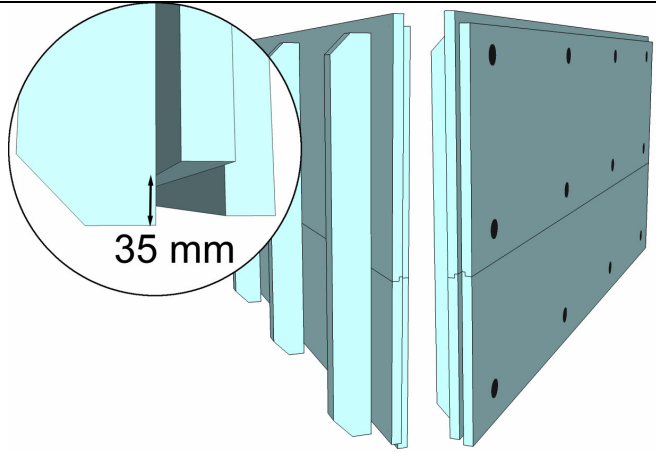

Attach the handles to the door with nylon screws from the inside.

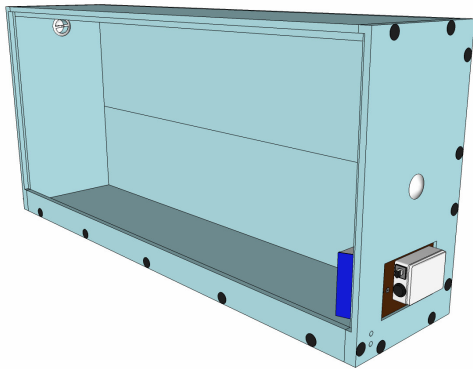

Install aggregate and ventilating valves.

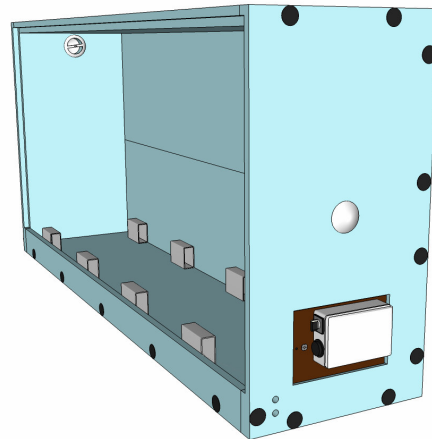

Place the bearing devices in such a way that the pressure against the floor of the kiln is widely spread.

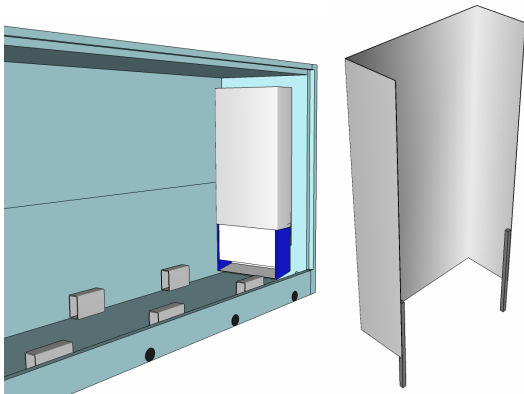

Make a simple intake duct from aluminium or stainless steel. There are several ways to fix the duct to the sidewall, but here the duct is equipped with two pins that are placed behind the aggregate.

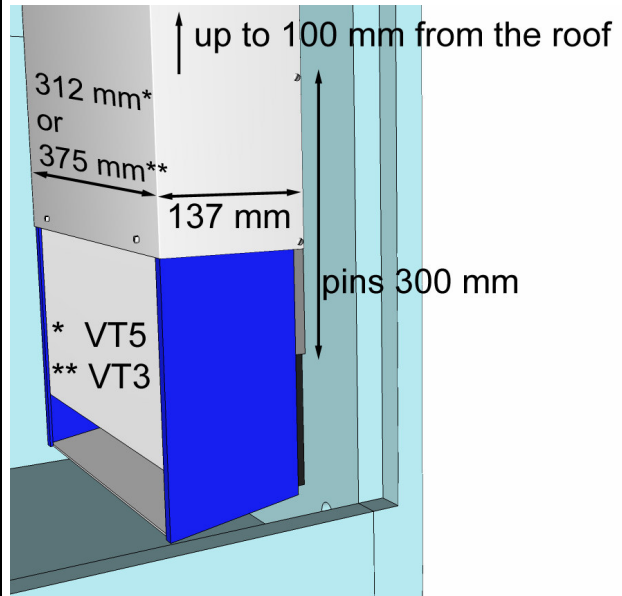

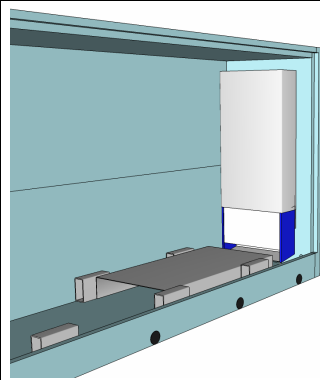

If the kiln is longer than 3 m, the air circulation can be too limited in the inner part of the kiln. The problem is solved with a channel of about 1/3 of the length of the kiln. It should be placed on the floor of the kiln, 50-100 mm from the aggregate.

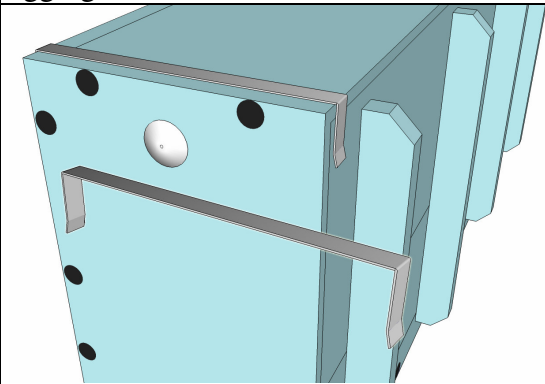
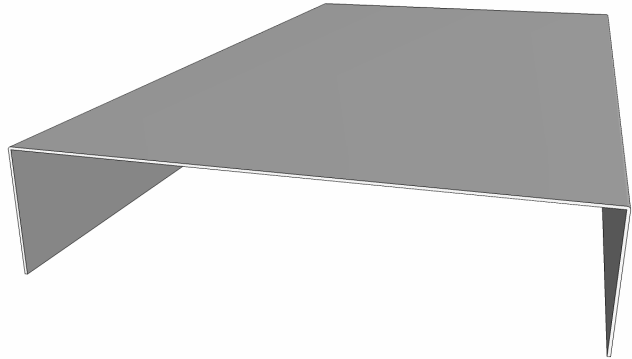

As the inner side of the kiln is much warmer than the outside, the inner side expands and the door is bent inwards. Sealing strips around the door opening will still keep the kiln tight. The upper corners can be critical points on long kilns. Simple hooks made from the insulation boards or wood will keep the door closed.

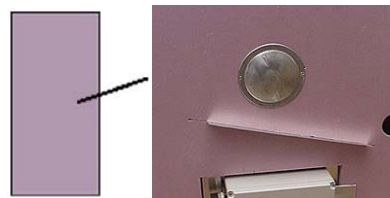
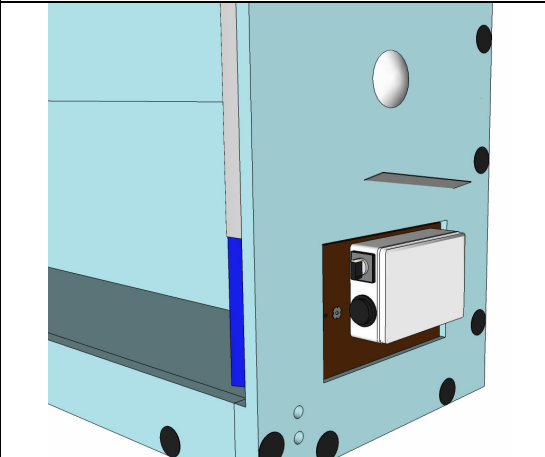
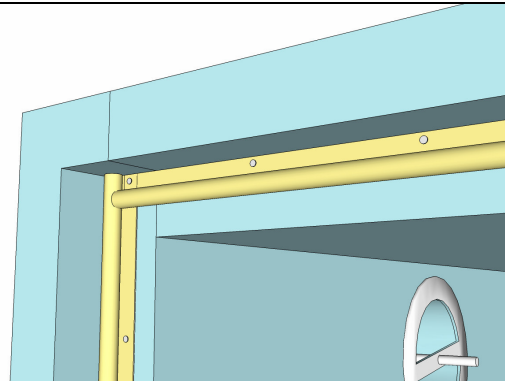
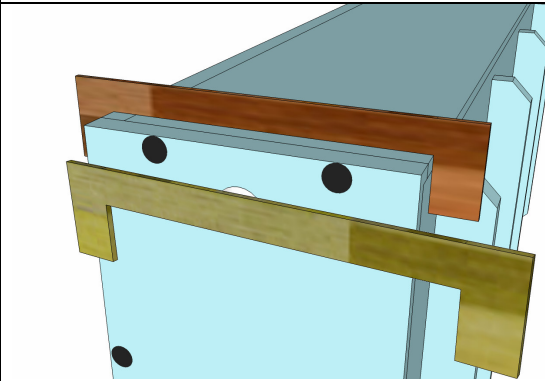

It can happen that condensed water drips from the ventilating valve. In order to prevent it from damaging the aggregate, you can make an oblique notch in the wall and insert a piece of sheet metal.



There are digital oven thermometers available for reasonable prices. You can buy one of those and just press it through the wall.

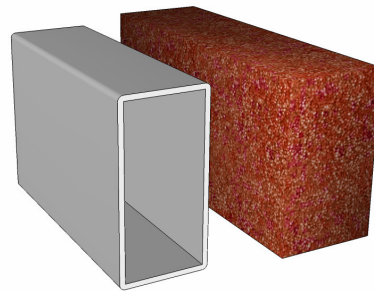

The bearing devices ought to be about 100 mm high.

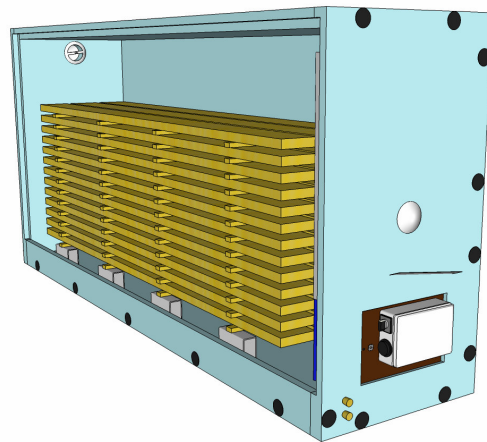
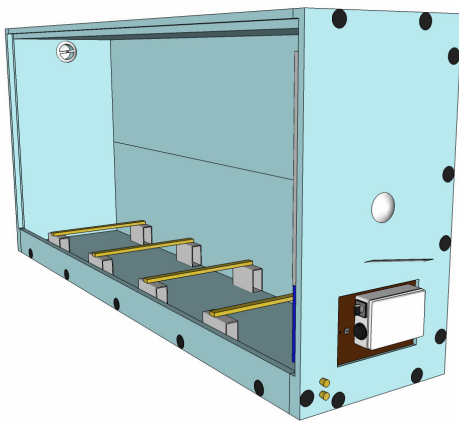

The timber is placed on bearing devices which allow the circulating air to blow under the timber. The bearing devices can be made from bricks and be connected with stiff wooden crossbars or alu-profiles. Make sure that the kiln stands on a steady bedding, because otherwise the floor of the kiln will be damaged.

Placing.

The kiln can be placed both indoors and outdoors. The aggregate must be protected from rain and snow when placed outdoors. A problem with indoor placing is that some kinds of wood smell rather strong when they are heated. Some moisture can come out of the kiln during the steaming process, but not more than normal ventilation will take care of.

Choice of aggregate.

VT3. Works for kilns with a maximum length of 3 m and a total inner volume of 3,5 m³.

VT5. Works for kilns with a maximum length of 5 m and a total inner volume of 12 m³

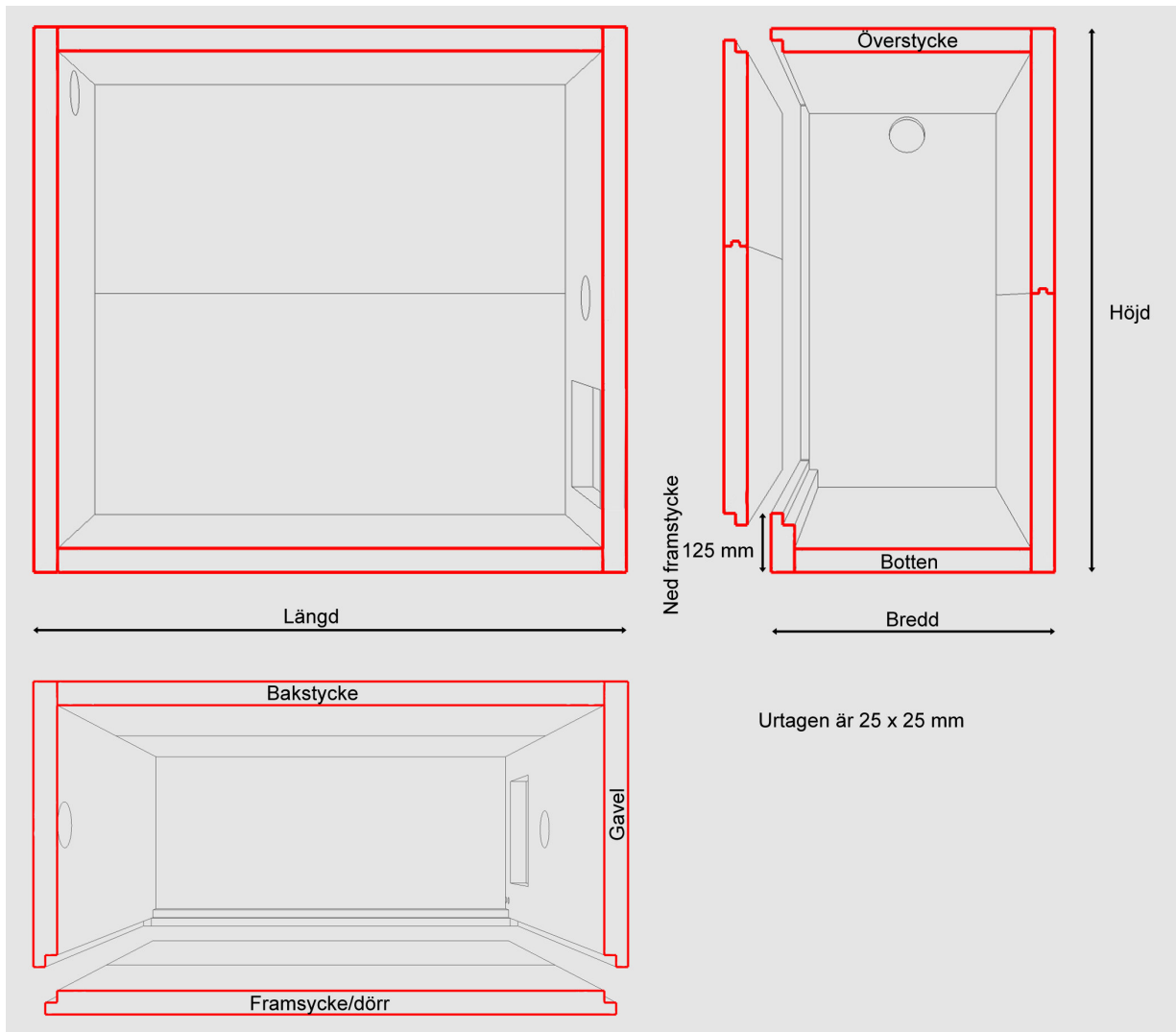

In order to make a kiln according to this description, but using other measurements, you can use the pattern below. Fill in your own desired measurements of L (length), W (width) and H (height) in order to get the correct size of insulation sheets. The thickness of the insulation boards is postulated to be 50 mm.

L = ..2450...mm	W = ..600.....mm	H = ..1150.....mm
Description	Length	Width
Floor	L - 100 mm = 2350 mm	W - 100 mm = 500 mm
Roof	L - 100 mm = 2350 mm	W - 50 mm = 550 mm
Sidewalls	H = 1150 mm	W = 600 mm
Back wall	L - 100 mm = 2350 mm	H = 1150 mm
Door	L - 50 mm = 2400 mm	H - 125 mm = 1025 mm
Sill	L - 100 mm = 2350 mm	125 mm

The kiln in this description, 2,45 x 0,6 x 1,2 m, needs about 40 nylon screws.

Instruction manual for the Sauno kiln dryer

Preparations:

- The timber is stacked on the bearing devices with piles between each layer. The piles shall be at least 5 mm thick and they must follow a vertical line.
- Close the drain in order to keep the water in the kiln.
- If you start from green wood (which is better because it has not started to crack) is it under normal conditions not necessary to add water. It is however no disadvantage to pour one or two buckets of water in the kiln if the volume of the wood is too small or if you are the least uncertain about the moisture content of the wood.
- If you start from seasoned wood is it necessary to fill water up to about 20 mm in the kiln.
- **Please note** that oak must be seasoned outdoors at least half a year in order to get rid of the corrosive acids that could destroy the aggregate.
- It is a good idea to insert a digital pyrometer through the wall of the kiln above aggregate and vent on the gable of the kiln (see building instruction)

1. The steaming process:

- Close the kiln and the ventilation valves. Adjust the thermostat switch to 50 and the power-level 2. Let the kiln work under these conditions for about 24 hours. The temperature in the kiln should now have reached 50-60°C. You can now switch the power level to 1 and change the thermostat step by step with a few degrees until the temperature reaches 70° C or a few degrees above that level. **Try to avoid to set the thermostat on a too high level. It can force the thermo fuse to cut out and stop the heating process until the temperature falls to 30° until the aggregate starts heating again.**
- Let the steaming process go on for about 4 days. Timber with a thickness of 75 mm or more will need 5-8 days. It is important to keep water on the floor during the entire steaming process because otherwise the timber can start cracking. Add water if necessary. Keep the overflow drain open during the steaming process.

2. The drying process:

- Open the floor level drain to get rid of the water.
- For softwood: Adjust the thermostat to 40 and adjust the thermostat step by step until you reach about 50°C in the kiln
- For hardwood. Adjust the thermostat to 30 and adjust the thermostat step by step until you reach about 40°C in the kiln (really hard wood may need even lower temperature to completely avoid cracking).
- Open the two ventilating valves about 5-8 mm. Check every day that you can feel some damp on the edge of the exhaust valve. If not, close the valve a little. If there is damp around the valve, you will know that the humidity in the kiln is high enough to admit the wood to dry from the interior of the wood. The wood will need at least two or three weeks to become dry enough to remain stable and reach the qualities that are necessary for perfect furniture. Check with a moisture meter that the moisture ratio at least has come down to 8 %.
- Let the timber rest 1-2 weeks indoors before using it. It needs to reach a balanced moisture ratio.

The Sauno method.

The Sauno method is a process in two steps. The first step is the steaming process at 70°-75° which opens the pores of the wood. The second step is the drying process. It happens at a temperature of 40°- 50° and the moisture is slowly evaporated from the centre of the timber. The risk for drying cracks is in that way reduced to a minimum.

Colour changes.

It is a well known fact that all kinds of timber are darkening slightly when heated. Sapwood (splint) and knots are changing more than heartwood. Modern solid wood driers are most often working with temperatures between 75°-110°C in order minimize the drying time.

The temperature in the Sauno kiln is 70°-75° during the steaming process, and the affect on the colour in that temperature range is limited.

It is a good idea to make drying tests with just small pieces of species you have never dried before if you are afraid that the colour will be affected in an unfavourable way.

In literature about timber drying you will often meet with the statement that “.... The limited affect on the colour of the wood at 70°-75° are in most cases favourable for all kinds of leaf wood...”

How the Sauno process is affected by the thickness of the timber and the kind of wood.

Soft wood

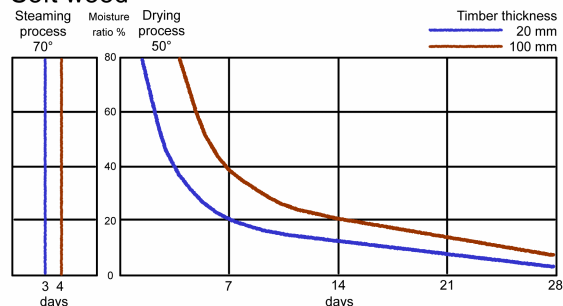

Hard wood

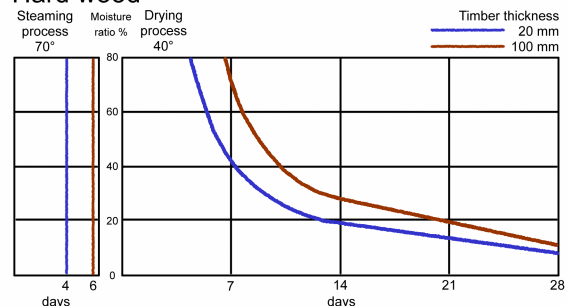

The curve chart shows the average time for the steaming process and the drying process with different assumptions. A fast increase of the ventilation will shorten the time for the drying process, but it will increase the risk for cracks.

A wood moisture meter will be of great help in checking the speed of the drying process.

In cases where it is difficult to calculate the time for the steaming process is it always better to better to add a day or two than to end the steaming process too early.

The steaming process will last as long for pre-dried wood as for green wood, because the wood has to be steamed all the way to the centre of the timber in both cases.

When drying timber of mixed thicknesses, both the steaming process and the drying process should be calculated for the thickest dimension.

Five weeks in Sauno or five years outdoors?

It is a well accepted fact that wood cannot dry faster than ten millimetres a year in order to minimize drought cracks. That knowledge is based on experiences from many generations, and it is as obvious in France as in Scandinavia despite the difference in climate conditions. Wood-carvers and wood-turners, who need thick material for their products, have anxiously watched their work pieces for many years in order to get material with a minimum of drought cracks. It may seem absurd to wait five years for a four-inch thick plank, but it is a reality they have lived with. The reason is that trees have cell-structures that efficiently prevent desiccation during dry periods or ground frost.

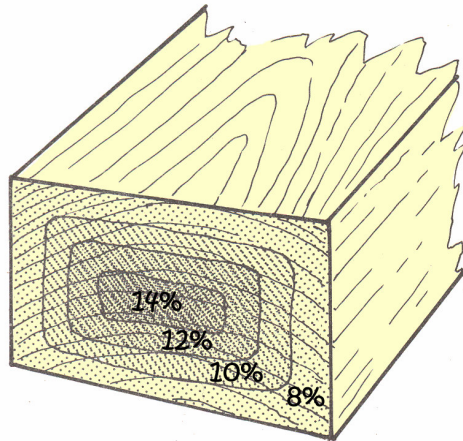

The striking thing is that these structures are working for so many years after the tree is cut down, and in that way preventing the humidity from coming out. When the drying process starts, the cells in the outer layer are the first to give up. As they are shrinking when drying, the outer „casing” becomes too narrow for the wet inner part. That is why the drought cracks appear.

If the drying process runs really slow, the humidity will slowly diffuse outwards and keep the cracking under reasonable control. The timetable is changed dramatically with Sauno. Five weeks is more than enough if the wood is 100 mm thick.

In addition to that the risk for drought cracks is strongly reduced in comparison with a five year long outdoor drying process.

The explanation is simple. At the temperature of 70-75°C during the steaming process, the locking structures are changed in such a way that humidity can move much faster all the way from the inner part of the wood and out. That is the reason why the drying process can be shortened to just a few weeks and yet produce wood with minimized drought cracks.

Almost everyone will agree that the theory speaks for Sauno, and so do all the pleased customers and the huge number of tests we have done since the first Sauno-prototype appeared 18 years ago.

We must agree that it happens now and then that a piece of wood is cracking, because some trees are grown in such a way that there are big tensions in the wood, and no drying method can solve that problem.

The drying of round-timber with a diameter of over 150 mm can be a lottery also with Sauno, especially if the rate of growth did accelerate during the life cycle of the tree. In that case the compact inner part of the stem shrinks much less than the diffuse sapwood, and the sapwood may crack.

Our long experience with Sauno has shown that it offers safer drying and reduces the cracking more than any other method we have tested. We have also noted that it creates wood with unique form stability.

The fact that the drying is fast and economic is a bonus that every owner of a Sauno takes part of. Everybody is a winner, but wood-carvers and wood-turners are probably the real winners. The timetable is radically changed and the risk to destroy valuable material is minimized.

Every bowl-turner can now rough-turn from green wood, and finish the turning within three weeks with much safer results than before.

